



## AUTOMATIC BIAS CONTROL TRANSMITTER SOLUTIONS

### USER MANUAL



P/N ABC-BPC-1x-x, x: Wildcard, applies to all instruments

Status: 2024-12-19  
Applies to Firmware 2.3.0 or later

info@id-photonics.com  
id-photonics.com



# CONTENT

1	General Information	3
2	Introduction	5
3	Quick Start	8
4	Connecting a host PC to the unit	13
5	Detailed Description of unit	16
6	Control loop	23
7	Troubleshooting and validation	26
8	Remote Control	32



# 1 GENERAL INFORMATION

## 1.1 MANUAL DOWNLOAD

The most current version of the manual can be downloaded in the resource area of our website. Request a login via the website to access the protected content.

## 1.2 COMPLIANCE STATEMENT ELECTROMAGNETIC COMPATIBILITY AND DEVICE SAFETY

(Models ABC-BPC-13-x, ABC-BPC-14-x, ABC-BPC-15-x only)

Hereby, we declare that this system has been designed and tested for compliance for the following directives.

### 1.2.1 INTERNATIONAL

IEC 62368-1

CISPR 11:2003 in accordance with EN 61326-1: 2006

### 1.2.2 UNITED STATES OF AMERICA

FCC 47 CFR Part 15, Subpart B Class A, Measurement process ANSI C63.4 (2009)

### 1.2.3 EUROPEAN UNION

EN 55022:2011

EN 61326-1: 2013

EN 61000-6-2: 2006

EN 61000-6-4: 2011

EN 61000-3-2: 2010

EN 61000-3-3: 2009

## 1.3 LIMITATION OF COMMUNICATION INTERFACES

Operation of all USB Ports is limited to a maximum cable length of 3 m and a maximum length of 30 m for all Ethernet ports present.

## 1.4 EUROPEAN WEEE DIRECTIVE COMPLIANCE

ID PHOTONICS has established processes in compliance with the Waste Electrical and Electronic Equipment (WEEE) Directive, 2002/96/EC. This product should not be disposed of as unsorted municipal waste and should be collected separately and disposed of according to your national regulations. In the European Union, all equipment purchased from ID PHOTONICS can be returned for disposal at the end of its useful life. ID PHOTONICS will ensure that all waste equipment returned is reused, recycled, or disposed of in an environmentally friendly manner, and in compliance with all applicable national and international waste legislation. It is the responsibility of the equipment owner to return the equipment to ID PHOTONICS for appropriate disposal. If the equipment was imported by a reseller whose name or logo is marked on the equipment, then the owner should return the equipment directly to the reseller. If you have questions concerning disposal of your equipment, contact ID PHOTONICS's at [WEEE@id-photonics.com](mailto:WEEE@id-photonics.com).

## 1.5 LINE VOLTAGE SELECTION

The unit operates from a DC power source that supplies any voltage 9 – 36VDC with a minimum output power of 30W transient and 10W typical during operation. Make sure that the power supply supports transient currents of at least 3A.

If a line power supply was delivered with the unit, it will automatically adapt to any AC Voltage ranging from 100V to 240V, 50/60Hz. Only use the supplied power supply to operate the unit.

## 1.6 HELP AND USER FEEDBACK

ID Photonics GmbH is dedicated to continuously improve customer experience of our products. Thus, if you have any feedback that might help us to improve our products send us an E-Mail to:

[feedback@id-photonics.com](mailto:feedback@id-photonics.com) .



## 1.7 SAFETY

### 1.7.1 GENERAL SAFETY PRECAUTIONS

The following general safety precautions must be observed during all phases of operation of this instrument. Failure to comply with these precautions or with specific warnings elsewhere in this manual violates safety standards of design, manufacture, and intended use of the instrument.

Before operation, review the instrument and manual for safety markings and instructions. You must follow these to ensure safe operation and to maintain the instrument in safe condition.

#### NOTE

**ID Photonics assumes no liability for the customer's failure to comply with these requirements**

### 1.7.2 GENERAL

This product is a Safety Class 1 instrument (provided with a protective earth terminal). The protective features of this product may be impaired if it is used in a manner not specified in the operation instructions.

### 1.7.3 ENVIRONMENT CONDITIONS

This instrument is intended for indoor use in an installation category II, pollution degree 2 environments. It is designed to operate at a maximum relative humidity of 95% and at altitudes of up to 2000 meters. Refer to the specification tables for the ac mains voltage requirements and ambient operating temperature range.

#### NOTE

Before connecting electrical power to the unit, make sure the unit could acclimatize to ambient temperature for at least 2 hours to avoid damage by i. e. condensed humidity on electrical parts inside the unit.

### 1.7.4 DO NOT OPERATE IN AN EXPLOSIVE ATMOSPHERE

Do not operate the instrument in the presence of flammable gases or fumes.

### 1.7.5 SAFETY SYMBOLS ON INSTRUMENTS

#### 1.7.5.1 WARNING OR CAUTION



If you see this symbol on the product, you must refer to the manuals for specific Warning or Caution information to avoid personal injury or damage to the product.

#### 1.7.5.2 ESD SAFETY WARNING



This sign indicates that the respective modules, boards or RF inputs and outputs are susceptible to damage by electro static discharge (ESD), and require proper protection procedures for storage and handling.

## 2 INTRODUCTION

### 2.1 MACH ZEHNDER MODULATOR - THEORY OF OPERATION

Mach-Zehnder modulator structures are a popular way of modifying the intensity or phase of light waves that are based on a Mach Zehnder interferometric setup. The light is split, guided in 2 distinct paths and combined again to achieve interference. Utilizing materials with a strong electro optical effect allow changing the relative phase of the optical carrier waves that are converted into intensity changes by means of interference at the output achieving a modulation of the light.

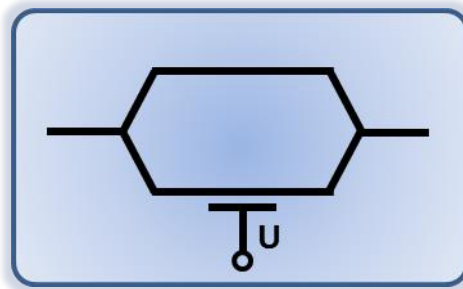

The power transfer curve of a single MZM as a function of applied voltage is shown below.

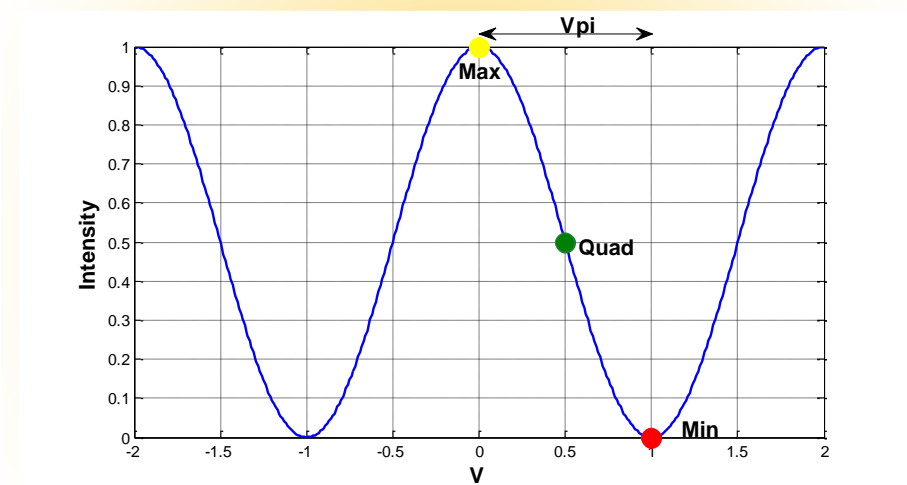

The Voltage change required to change the output power from maximum to minimum or vice versa is defined as  $V_{\pi}$  ( $V\pi$ ). The mid-point between maximum and minimum transmission is defined as Quadrature (Quad).

### 2.2 AUTOMATED BIAS CONTROL

This unit is used to set the BIAS Voltage of Mach Zehnder Modulators (MZM) to its optimal operating point by means of dither tones imposed onto the BIAS Electrodes and feedback signals generated from a photodiode monitor tap located after the MZM components.

A key feature is the independence of the applied modulation format for IQ Modulator control supporting advanced modulation formats such as Nyquist shaped signals, QAM, SSB and pre-distorted signals. Furthermore, a BIAS optimization is possible without a RF signal present.

The control loop utilizes feedback signals derived from a feedback photodiode located after the MZM by means of dither tones that are applied to the BIAS electrodes of the MZM.

It supports the usage of Photodiodes that are built into the MZM package (internal) or discrete Photodiodes that are connected by means of an external tap coupler (external). The functional diagram below shows a typical configuration for a dual Pol IQ Modulator setup using a Super MZM structure of 2 nested MZMs used for I and Q modulation:

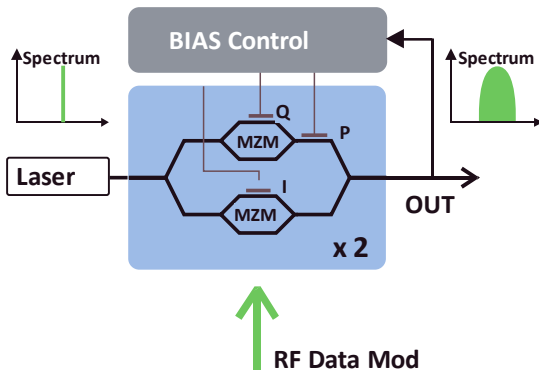

The following configurations are supported by the board (x: supported, “-“: not supported/available”):

MZM TYPE	INTERNAL PHOTODIODES		EXTERNAL PHOTODIODES		APPLICATION EXAMPLE
	1 PD	2 PD	1 PD	2 PD	
Single Polarization IQ Modulator <sup>1</sup> (SPIQ mode)	✓	-	✓	-	SP-QPSK, SP-QAM32
Dual Polarization IQ Modulator (DPIQ mode)	(-)	✓	✓	(✓)	DP-QPSK, DP-QAM16
Single Polarization Intensity Modulator (II) <sup>2</sup> (SPII mode)	✓	-	✓	-	SP-OOK, SSB
Dual Polarization Intensity Modulator (II) (DPII mode)	(-)	✓	✓	✓	DP-OOK, DP-Multi-Level

The architecture of the control is mostly software based allowing a maximum of performance, versatility and configurability.

<sup>1</sup> Up to 2 Modulators can be operated using a single ABC board. Configure a Dual Pol. IQ modulator and 2 Photodiodes for this case

<sup>2</sup> Up to 2 Modulators can be operated using a single ABC board. Configure a Dual Pol. II modulator and 2 Photodiodes for this case

## 2.3 OVERVIEW AND FUNCTIONAL BLOCKS

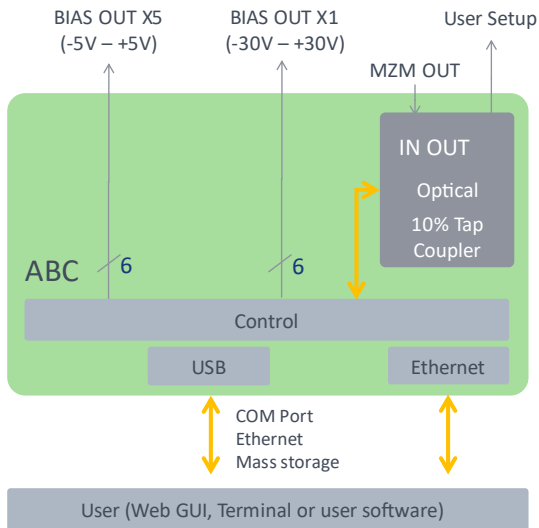

### 2.3.1 USER INTERFACES

A USB interface or an Ethernet interface can be used to communicate with the unit. The unit hosts a web server unit so that instant installation free access using any state-of-the-art browser is possible.

The USB Interface provides 3 modes of access:

1. Virtual Serial Port
2. Virtual Ethernet interface
3. Virtual USB stick containing manual, drivers, etc.

### 2.3.2 MACH-ZEHNDER BIAS INTERFACES

The unit provides 2 output terminals to cover different BIAS Voltage ranges. Both outputs are electrically separate but are fed in parallel by the DAC outputs. Thus, the two interfaces contain the same value but scaled in a relative to their corresponding output swing.

Socket X1: -30V to +30V differential or -15V to +15V Single Ended

Socket X5: 0V to +5V Single Ended

PHD1, PHD2 Photodiode 1 & 2 Inputs are non-biased inputs with wide range transimpedance conversion on the board. Either 1 or 2 inputs are used depending on the configuration used.

For more details on the control loop see chapter 0.



### 3 QUICK START

We propose to perform the following steps to set up the Automated BIAS Control (ABC) with your setup:

Connect the user interface of preference (USB or Ethernet) to your host computer. For details how to connect a host PC, see section 0.

The following steps depend on the MZM type you wish to connect to the unit.

#### 3.1.1 OIF STANDARD COMPATIBLE DUAL POL IQ MZM

Connect the MZM module to the small supplied daughter board.

Connect the daughter board via the ribbon cable to X1 and PHD1/2 of the main board.

If an OIF Standard compatible Dual Pol MZM with internal monitor diodes such as the Fujitsu FTM797xHQx is to be used, plug the MZM into the small on the small child board and connect the child board using the supplied ribbon cable to connector X1 on the ABC board.

The picture shows a typical connection setup using a OIF compliant DualPol IQ MZM and MZM internal photodiodes. For optimum performance, use a separate external PD for feedback signal generation.

Bare Board ABC-BPC-11-x – Extension Board V1

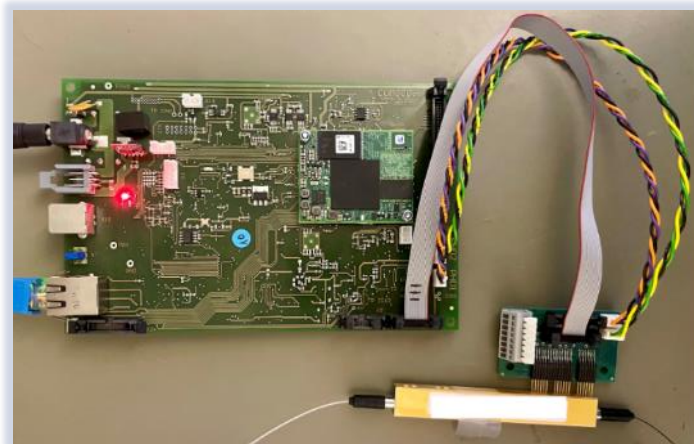

Bare Board ABC-BPC-11-x – Extension Board V2

Connect X1, leave X7 (SuB-D) unconnected

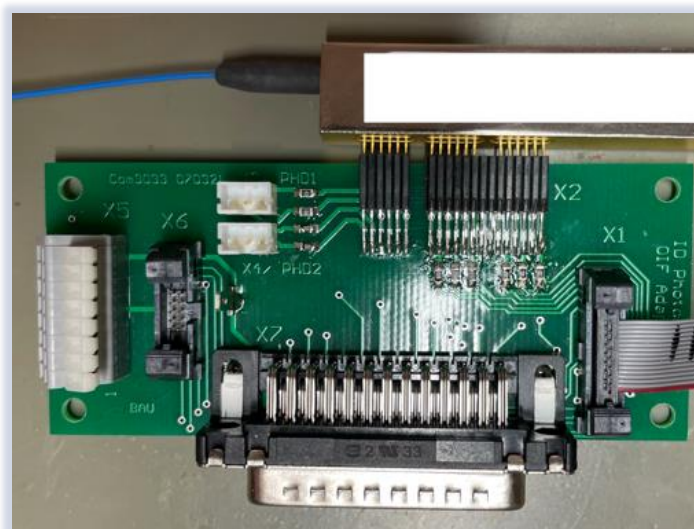





## Benchtop Unit ABC-BPC-13-x, Single PD feedback

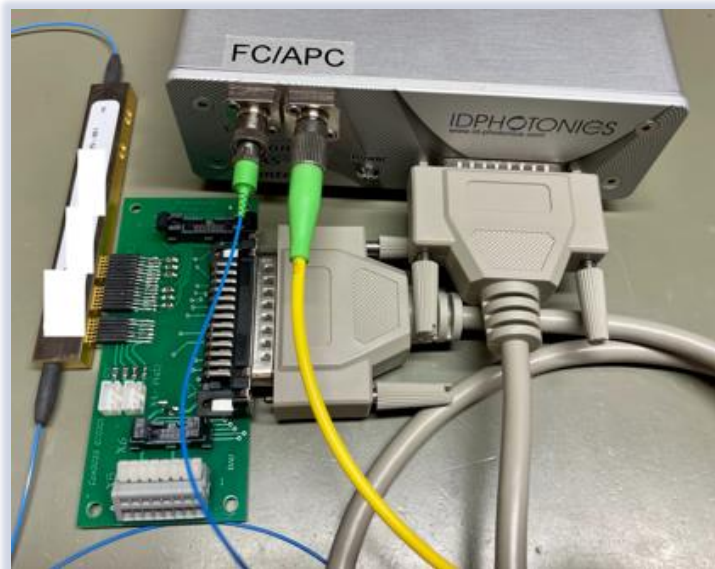

Connect X7 (SuB-D), connect MZM Optical out to “IN” of ABC unit. Connect “OUT” to your setup.

1. Connect and enable the output of laser light source to the MZM.  
In case of a separate feedback PD (i. e. ABC-BPC-13-x, ABC-BPC-14-x) connect the output of the MZM to the PDs. In case the MZM built-in feedback PD is used (ABC-BPC-11-x, ABC-BPC-15-x) and OIF compatible MZM, the PD connection is made via the adaptor board.
2. Switch on the ABC unit by plugging in the power supply into the socket
3. Wait for ~30seconds to start up the board
4. If USB and Win 10 is used, the drivers will install automatically. There are 3 drivers installed:
  - a. Virtual Ethernet
  - b. Virtual Serial Port
  - c. Virtual Mass Storage device
5. Connect to the GUI, for details see 0.
6. Per default, the bare board is set to 2 channel PD feedback using an IQ modulator with Quad/Min/Min BIAS setting. The benchtop unit default is set to the number of PD feedback channels installed in the device.
7. Click on “VPI setting” and enter the VPI Voltages of the BIAS Terminals of your MZM.
8. Now, in MZM tab, enable the control via button “ABC”. The unit should run through its init sequence. After 30 – 200seconds it should settle (Indicator “ABC settled”). A proper control loop connection is characterized by fast but gradual moves of the voltages followed by a slowing down, saturation like, approach to the target (PI control loop). See reference graph in section 7.

### 3.1.2 +/-30V DIFFERENTIAL AND +/-15V SINGLE ENDED OUTPUT

(Default is +/-30V differential)

Usage of these outputs for non-standard OIF MZMs requires a customized connection to the board. For a block diagram of potential setups, see section 6.1.

We recommend to connect the daughter board via the ribbon cable to X1 to the main board and use the terminals of the connector highlighted with 1 to build a custom connector cable to your MZM. See 0 for pinning of this connector.

Depending on setup, connect 1 or 2 feedback photodiodes with PHD1 and/or PHD2 on the main board. For the benchtop unit, check the number of feedback channels on the front of the unit. 2 connectors (type ABC-BPC-13-x) is a single PD unit, 4 connectors (type ABC-BPC-14-x) is a dual PD unit.

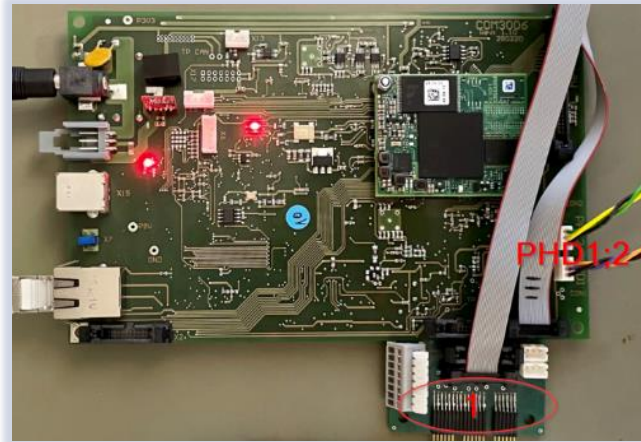

1. Connect and enable the output of laser light source to the MZM.
2. Switch on the ABC board by plugging in the power supply into the socket
3. Wait for ~30seconds to start up the device
4. If USB and Win 10 is used, the drivers will install automatically. There are 3 drivers installed:
  - a. Virtual Ethernet
  - b. Virtual Serial Port
  - c. Virtual Mass Storage device
5. Connect to the GUI, for details see 0.
6. Make sure the ABC is in Manual mode. In connection tab, enter password "IDP" to elevate the user level to 1. Go to system tab, select the required mode for your setup in "ABC config" tab. Select "X1 differential" or "X1 single ended" mode in drop down "Display output range for port".
7. Click on "VPI setting" and enter the VPI Voltages of the **BIAS** Terminals of your MZM.
8. Now, in MZM tab, enable the control via button "ABC". The unit should run through its init sequence. After 30 – 200seconds it should settle (Indicator "ABC settled"). A proper control loop connection is characterized by fast but gradual moves of the voltages followed by a slowing down, saturation like, approach to the target (PI control loop). See reference graph in section 7.



### 3.1.3 0 – 5V SINGLE ENDED OUTPUT

Connect to the small supplied daughter board via the ribbon cable to X5 (extension Board V1) or X6 (extension Board V2) on the main board

Depending on setup, connect 1 or 2 feedback photodiodes with PHD1 and/or PHD2 on the main board.

Use the grey MZM out hub connector block to connect MZM module. See 5.4.3 for the pinning of this hub.

Bare Board ABC-BPC-11-x – Extension Board V1

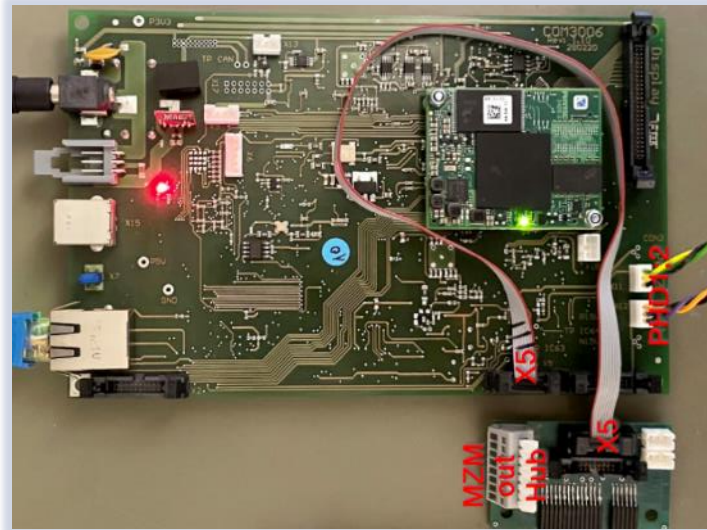

Bare Board ABC-BPC-11-x – Extension Board V2  
X6 in case of bard Board, X7 (Sub-D) in case of Benchtop

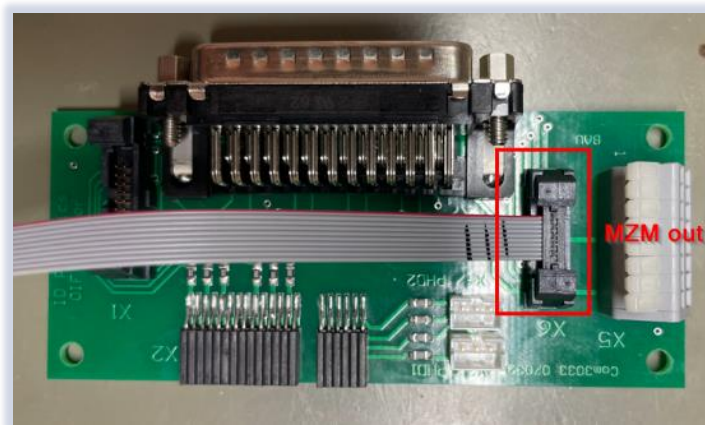

1. Connect and enable the output of laser light source to the MZM.
2. Switch on the ABC board by plugging in the power supply into the socket
3. Wait for ~30seconds to start up the board
4. If USB and Win 10 is used, the drivers will install automatically. There are 3 drivers installed:
  - a. Virtual Ethernet
  - b. Virtual Serial Port
  - c. Virtual Mass Storage device
5. Connect to the GUI, for details see 0.
6. Make sure the ABC is in Manual mode. Go to system tab, enter “IDP” in connection tab to elevate the user level to 1. Select the required mode for your setup in “ABC config” tab. Select “X5 0–5V” mode in drop down “Display output range for port”.



7. Now, in MZM tab, enable the control via button “ABC”. The unit should run through its init sequence. After 30 – 200seconds it should settle (Indicator “ABC settled”). A proper control loop connection is characterized by fast but gradual moves of the voltages followed by a slowing down, saturation like, approach to the target (PI control loop). See reference graph in section 7.

### 3.2 QUICK START – REMOTE CONTROL

This section contains redundant information from other chapters but is useful for a first-time usage of the instrument.

1. Wait until the boot sequence is completed.
  -
2. Connect the USB Port located at the rear of the unit to your Windows10 PC or connect the Ethernet Port to your LAN.
  - - a. **For USB** based access, all drivers will be installed automatically, Windows device manager should show now 3 devices:
      1. A storage device containing manual etc.
      2. A virtual Ethernet Interface “RNDIS”
      3. A virtual COM PortBoth virtual COM and Ethernet Ports can be used to remote control the unit. The installed COM Port number can be retrieved from Windows device manager. The IP address by the command shell “ping abc.local”.
    - - b. **For Ethernet** based access, the default IP of the unit is 192.168.0.1. Make sure that the host PC IP is in the same subnet as the laser unit (192.168.0.x). If this is not the case, you can change the IP settings of the unit via the touch screen or using the USB Port of the unit. Use “abc.local” as an alternative to the IP address to connect to the unit.
3. Open your Web browser, enter “abc.local” in the address field and hit <enter>. The Webpage allowing to control the laser remotely should open now.

#### NOTE

Depending on the configuration of your host PC DNS structure, the “abc.local” name representation might not be resolved into the correct IP address. In such a case, open a connection to the USB virtual serial interface (COM Port) and type the command “USBIPADDR?;” to retrieve the USB IP Address or “IPADDR?;” for the IP address of the physical Ethernet interface.



## 4 CONNECTING A HOST PC TO THE UNIT

This section contains more in-depth information on how to setup the remote interfaces on a host PC and basic principles of the laser.

### 4.1 ETHERNET CONNECTION

This section covers connectivity using Ethernet, skip it if you plan on using USB.

The default IP address is 192.168.0.1, DHCP off. If you plan to connect using the Ethernet interface, make sure the host PC is within the same subnet as the ABC Ethernet Interface (The PC IP Address is 192.168.0.x then). The connectivity can be tested by opening a command shell (type “cmd” in windows search field and hit <enter>, a

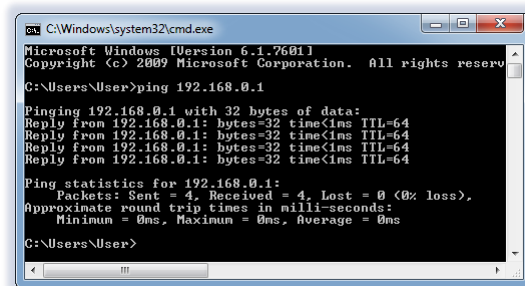

“black window with a DOS shell should open) and executing the command “ping 192.168.0.1”.

#### 4.1.1 CHANGE OF PHYSICAL ETHERNET IP ADDRESS WITHOUT GUI ACCESS

If you do wish to change the IP settings of the unit, we recommend first connecting via USB and changing the IP settings via USB connection. Use the virtual serial port (COM Port) to connect to the unit.

Use the command “ipaddr xxx.xxx.xxx.xxx” to set a new IP address where xxx.xxx.xxx.xxx is the IP address you wish to use. You can query the IP address via “ipaddr?”. For further IP address settings, refer to the remote section. Note that the unit must be rebooted in order for the new IP setting to become effective. Use command “\*rst” for that.

Note that changing the IP address requires the user to be connected with user level 1 or higher. Send the command “pass IDP” or enter the password “IDP” in the GUI to elevate the user level to 1. This change will require a reboot (soft reset of the unit) to become effective.

#### 4.1.2 OPENING A REMOTE CONNECTION VIA ETHERNET

The device supports a session based remote access on Port #2000.

Start the terminal program “putty.exe” supplied with the unit or use any other terminal program.

Set the following parameters in Putty and open the connection:

Alternatively to the default IP Address shown above, enter “abc.local” or the IP address currently set to the unit. If in doubt, use the touch panel display “Device config” – “IP config” to retrieve the actual IP Address.

Note that there must be a valid route on the IP layer between the device and the host PC (i.e. the ethernet port of the host PC is set to the same subnet as the device, for example 192.168.0.2)

must be established before continuing. Use a command shell and command “ping abc.local” to test the route.

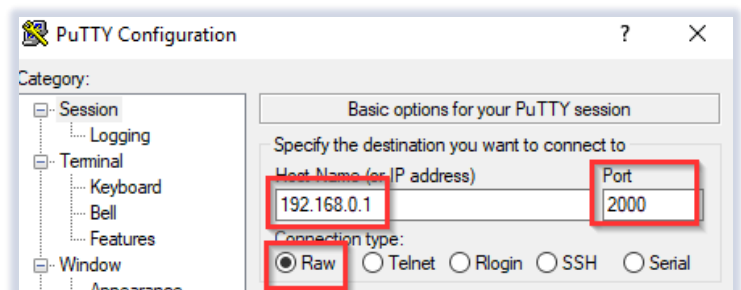



Once the connection is established, type in “\*idn?” and hit <ENTER>. The unit responds with its \*idn? String.

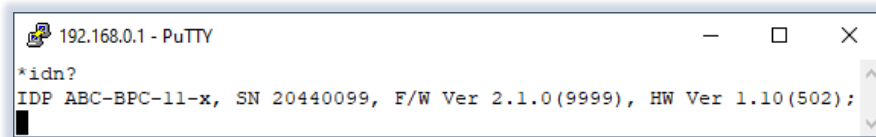

```
192.168.0.1 - PuTTY
*idn?
IDP ABC-BPC-11-x, SN 20440099, F/W Ver 2.1.0(9999), HW Ver 1.10(502);
```

Alternatively, a request based remote control via http Port 80 is possible. To test this, open a browser window and type the following string into the address field:

[http://abc.local/scpi/\\*idn?](http://abc.local/scpi/*idn?)

For more details, see section 8.2.

## 4.2 USB CONNECTION

This section covers connectivity using USB, skip it if you plan using Ethernet.

Once the unit is powered up and the USB cable is connected to the host computer for the first time, a new device installation should be triggered automatically within Windows.

Once installation is complete, three devices are installed on the host computer:

1. Virtual Ethernet Interface
2. Virtual COM Port
3. Virtual Storage device that contains resources such as manual and programming devices as well as drivers for Windows 7.

### 4.2.1.1 WINDOWS 10

Windows 10 will automatically install 3 devices allowing to connect the unit

1. A virtual Ethernet interface (RNDIS)
2. A generic virtual COM port driver “Serial USB device”. If you have several COM ports installed in the host PC, you may want to note the COM Port number under which the unit got installed. For further details on USB connection, see section 4.2.1.3.
3. A storage device similar to an USB Stick containing resources for the laser unit

The virtual COM Port and the virtual Ethernet interface are concurrent ways to access the unit for remote control. The web-based control is automatically accessed via entering “abc.local” into your browser.

### 4.2.1.2 WINDOWS 7

Windows 7 will install the same structure as described in the windows 10 section above. It will automatically install a virtual Ethernet interface (RNDIS) and the USB storage device (“Linux File- Store Gadget USB Device”). However, it does not have a preconfigured driver setup for the virtual COM Port. It will try to locate a driver for the unit on the host PC first and then check online. Stop the search and select the option “Install a custom driver”.



Point the installation routine to the driver located on the USB storage device provided by the unit in directory “USBDriverWin7” and select file “ABCUSBSerialDriverWindows7.inf” in this folder. If the installation has been completed already, open Windows Device Manager, locate “CDC Serial”, right click on it and select “Update driver”. Proceed as described before.

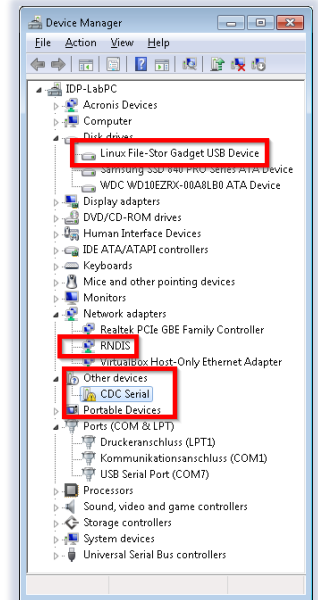

Continue with the installation routine. Once installed, the virtual COM port should appear in Windows Device Manager as shown below as IDP ABC. The COM Port number will be different for your system. Note down the number for later usage in remote control applications.

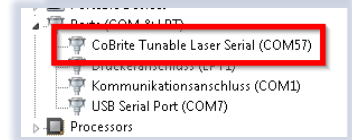

#### 4.2.1.3 CONNECTION TO THE DEVICE VIA USB VIA HOST PC

Once installed properly, the USB connection provides a virtual COM Port and a virtual Ethernet Port to the instrument. To access the unit via virtual Ethernet, follow the instructions as in section 4.1.2 but note that the IP Address of the unit will be different as for the physical Ethernet Port. To access to the unit using the virtual COM port, open a terminal window using the installed COM port number per description above.

### 4.3 INSTALLATION OF CONTROL SOFTWARE

This instrument does not require any installation of software for operation. Once connected to a host PC or a local network, simply enter “abc.local” into the address field of your Web browser to access the unit.

#### 4.4 WHAT IF “ABC.LOCAL” CANNOT BE REACHED BY HOST COMPUTER?

Depending on the configuration of your host PC DNS structure, the “abc.local” might not be resolved into the correct IP address. In such a case, open a connection to the virtual serial interface (COM Port) and type the command “USBIPADDR?;” to retrieve the IP Address for USB connection and “IPADDR?;” for physical Ethernet.

After retrieving the address, enter the corresponding IP address into your browser address field to access the unit via GUI.



## 5 DETAILED DESCRIPTION OF UNIT

### 5.1 BARE BOARD VERSION ABC-BPC-11-X

The picture below gives an overview of the Main Board. All available connectors and features are described in the next sections.

The output to the MZM is supplied at the connectors X1 and X5 located on the upper left-hand side. Both outputs are electrically independent but are fed by the control electronics (DACs) in parallel.

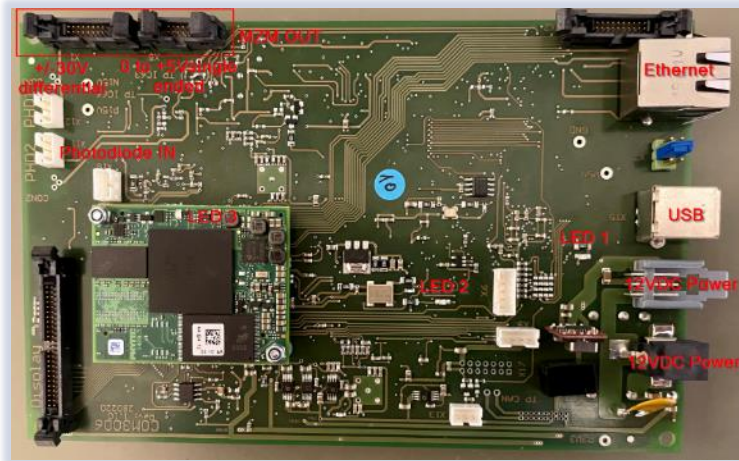

#### 5.1.1 STATUS LEDS

LED 1: Is a power indicator. It will light as long as Power is supplied to 12VDC Power jacks.

LED 2: Is a heartbeat indicator

LED 3: Located on the Main CPU daughter board indicates activity of the main CPU. It is solid green at time of startup and will start to flash when ready.

#### 5.1.2 BIAS OUTPUT CONNECTORS

Note that the 2 output connectors X1 and X2 are parallel outputs. They will exhibit the same scaled Voltages independent of the setting the output in the software. The X1 terminals will always be ~3 or 6 times larger compared to respective voltages on X5. The software setting affects the display in the GUI only.

##### 5.1.2.1 CONNECTOR X1 - BIAS OUT 1

This connector provides a voltage range of -15V to +15V if used single ended. In differential mode, the output range is consequently -30V to +30V.

For single ended use, connect the P terminals to the MZM electrode and the other to the common GND.

The output impedance of the terminals is 330Ohms.





PIN	DESCRIPTION
1	BIAS Channel 6 P (OIF Implementation: Q Mod; Y Polarization)
2	BIAS Channel 6 N (OIF Implementation: Q Mod; Y Polarization)
3	BIAS Channel 5 P (OIF Implementation: I Mod; Y Polarization)
4	BIAS Channel 5 N (OIF Implementation: I Mod; Y Polarization)
5	BIAS Channel 3 P (OIF Implementation: Q Mod; X Polarization)
6	BIAS Channel 3 N (OIF Implementation: Q Mod; X Polarization)
7	BIAS Channel 2 P (OIF Implementation: I Mod; X Polarization)
8	BIAS Channel 2 N (OIF Implementation: I Mod; X Polarization)
9	BIAS Channel 4 P (OIF Implementation: Phase; Y Polarization)
10	BIAS Channel 4 N (OIF Implementation: Phase; Y Polarization)
11	BIAS Channel 1 P (OIF Implementation: Phase; X Polarization)
12	BIAS Channel 1 N (OIF Implementation: Phase; X Polarization)
13	GND
15	GND
16	GND

### 5.1.3 CONNECTOR X5 - BIAS OUT 2

This connector provides a voltage range of 5V. The output impedance of the terminals is 120Ohm.

PIN	DESCRIPTION
1	BIAS Channel 2 (OIF Implementation: I Mod; X Polarization)
2	BIAS Channel 5 (OIF Implementation: I Mod; Y Polarization)
3	BIAS Channel 3 (OIF Implementation: Q Mod; X Polarization)
4	Do not connect
5	BIAS Channel 6 (OIF Implementation: Q Mod; Y Polarization)
6	GND
7	BIAS Channel 4 (OIF Implementation: Phase; Y Polarization)
8	GND
9	BIAS Channel 1 (OIF Implementation: Phase; X Polarization)
10	GND

### 5.1.4 CON1, CON2, PHD1, PHD2 - CONNECTOR FOR EXTERNAL FEEDBACK PHOTODIODE

PIN	DESCRIPTION
1	Photodiode, Anode
2	Photodiode, Cathode, GND
3	GND



## 5.2 BENCHTOP VERSION ABC-BPC-13-X, ABC-BPC-13-X

The benchtop versions provide 1 or 2 optical in- and outputs. These are internally connected to a 5% single mode tap coupler of which the 5% path is connected to a photodiode that generates the feedback signal required to operate the ABC.

The front panel hosts a 25 Pin female Sub-D Connector providing the electrical signals for the Mach-Zehnder, a Power LED and the optical in- and output connectors.

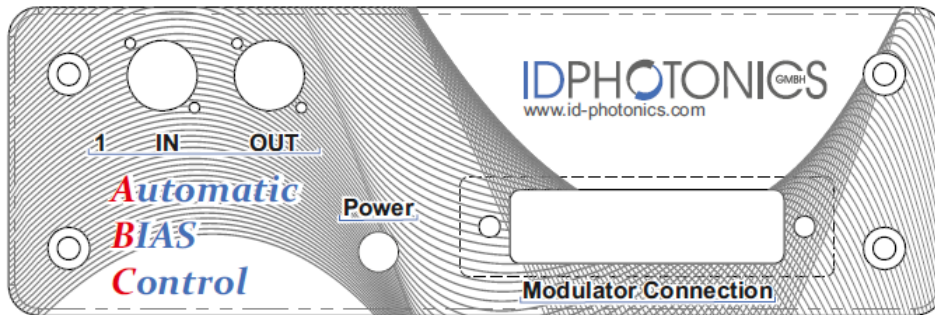

### 5.2.1 SUB-D CONNECTOR PINNING

PIN	DESCRIPTION
1	GND
2	+/-5V Range - BIAS Channel 1 (OIF Implementation: Phase; X Polarization)
3	+/-5V Range - BIAS Channel 4 (OIF Implementation: Phase; Y Polarization)
4	+/-5V Range - BIAS Channel 6 (OIF Implementation: Q Mod; Y Polarization)
5	+/-15V Range - BIAS Channel 6 P (OIF Implementation: Q Mod; Y Polarization)
6	+/-15V Range - BIAS Channel 6 N (OIF Implementation: Q Mod; Y Polarization)
7	+/-15V Range - BIAS Channel 5 P (OIF Implementation: I Mod; Y Polarization)
8	+/-15V Range - BIAS Channel 5 N (OIF Implementation: I Mod; Y Polarization)
9	+/-15V Range - BIAS Channel 3 P (OIF Implementation: Q Mod; X Polarization)
10	+/-15V Range - BIAS Channel 3 N (OIF Implementation: Q Mod; X Polarization)
11	+/-15V Range - BIAS Channel 2 P (OIF Implementation: I Mod; X Polarization)
12	+/-15V Range - BIAS Channel 2 N (OIF Implementation: I Mod; X Polarization)
13	+/-15V Range - BIAS Channel 4 P (OIF Implementation: Phase; Y Polarization)
14	+/-15V Range - BIAS Channel 4 N (OIF Implementation: Phase; Y Polarization)
15	+/-15V Range - BIAS Channel 1 P (OIF Implementation: Phase; X Polarization)
16	+/-15V Range - BIAS Channel 1 N (OIF Implementation: Phase; X Polarization)
17	Not connected
18	Photodiode 2, Anode
19	Photodiode 2, Cathode
20	+/-5V Range - BIAS Channel 3 (OIF Implementation: Q Mod; X Polarization)
21	Photodiode 1, Anode



22	Photodiode 1, Cathode
23	+/-5V Range - BIAS Channel 5 (OIF Implementation: I Mod; Y Polarization)
24	+/-5V Range - BIAS Channel 2 (OIF Implementation: I Mod; X Polarization)
25	GND

### 5.3 REAR PANEL

The rear panel provides the electrical power socket and communication interfaces.

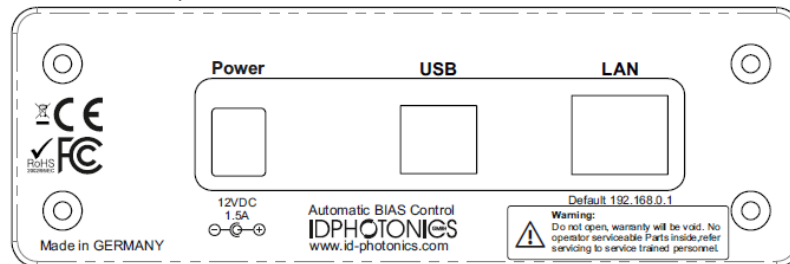

The Power socket is used to power the device. Use only the supplied power supply provided with the unit.

USB is a standardized interface that can be used to connect to USB Hosts standardized by USB Implementers Forum (USB-IF). Make sure to only connect devices that are compliant to this standard.

The Ethernet interface complies to IEEE 802.3 standard. Make sure to only connect devices that are compliant to this standard.

### 5.4 MZM CONNECTOR EXTENSION BOARD

There are 2 Versions of the extension board. Refer to the applicable part for your board at hand.

#### 5.4.1 CONNECTORS X1, X6, X7 CONNECTORS TO MAIN UNIT

These connectors are used to connect to the main unit.

The pinning of X1, X6 and X7 (Sub-D V2 only) is identical to the pinning defined for the mainboard or benchtop device since they connect via the grey ribbon or the SUB-D jumper cable.

V1 Extension Board

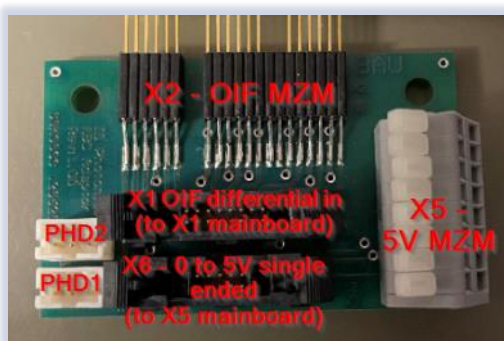

V2 Extension Board



#### 5.4.2 CONNECTOR X2 - OIF COMPATIBLE DP-IQ MZM

This board can be used if an OIF Standard compatible such as the Fujitsu FTM797xHQx series. The 100kOhm resistors located on board are switched in parallel to the BIAS electrodes. They are used to reduce the local impedance of the BIAS electrodes and help to reduce ripple pickup that may be introduced by the extension cables.

For this configuration, connect X1 for the MZM out signals coming from the main board.

Connect PHD2 and PHD1 Photodiode sockets to the corresponding sockets on the main board.

The MZM connector layout meets the OIF Standard definition, see



<https://www.oiforum.com/wp-content/uploads/OIF-PMQ-TX-01.1.pdf>

### **! NOTE**

The OIF Pin numbering definition does count RF Inputs (1-4). Furthermore, space between 3 groups equaling to 2 pins pitch is NOT counted by OIF.

The default usage is differential mode. For single ended usage, connect the corresponding P channel and GND to the electrodes of the MZM.

See section “Remote Control” for channel assignment to BIAS Electrodes.

PIN	OIF PIN	DESCRIPTION
<b>SECTION 1</b>		
1	5	BIAS Channel 6 P (OIF Implementation: Q Mod; Y Polarization)
2	6	BIAS Channel 6 N (OIF Implementation: Q Mod; Y Polarization)
3	7	BIAS Channel 5 P (OIF Implementation: I Mod; Y Polarization)
4	8	BIAS Channel 5 N (OIF Implementation: I Mod; Y Polarization)
5	9	BIAS Channel 3 P (OIF Implementation: Q Mod; X Polarization)
6	10	BIAS Channel 3 N (OIF Implementation: Q Mod; X Polarization)
7	-	Not connected
8	-	Not connected
9	11	BIAS Channel 2 P (OIF Implementation: I Mod; X Polarization)
10	12	BIAS Channel 2 N (OIF Implementation: I Mod; X Polarization)
11	13	BIAS Channel 4 P (OIF Implementation: Phase; Y Polarization)
12	14	BIAS Channel 4 N (OIF Implementation: Phase; Y Polarization)
13	15	BIAS Channel 1 P (OIF Implementation: Phase; X Polarization)
14	16	BIAS Channel 1 N (OIF Implementation: Phase; X Polarization)
<b>SECTION 2</b>		
1	17	GND
2	18	Photodiode 1, Anode (OIF Implementation: Y Pol.)
3	19	Photodiode 1, Cathode (OIF Implementation: Y Pol.)
4	20	GND
5	21	Photodiode 2, Cathode (OIF Implementation: X Pol.)
6	22	Photodiode 2, Anode (OIF Implementation: X Pol.)

#### **5.4.3 CONNECTORS X2/3 – PHOTODIODE CONNECTORS**

These connectors are optionally used to connect the photodiodes inside of OIF compatible MZMs connected via X2 to the main board using the supplied 3 pin jumper cables to PHD1 and PHD2 on the main board. Use these only if you want to use the MZM internal photodiodes. We recommend to use a separate photodiode for optimal performance.



### 5.4.4 CONNECTOR X5 - OTHER CONFIGURATIONS (GREY CONNECTOR HUB)

The large grey connector hub hosts the -5V to +5V output signals coming from the main board. Set the Use the X5 connection cable to use this port. Pin 1 is located to the edge of the PCB.

PIN	DESCRIPTION
1	BIAS Channel 2 (OIF Implementation: I Mod; X Polarization)
2	BIAS Channel 5 (OIF Implementation: I Mod; Y Polarization)
3	BIAS Channel 3 (OIF Implementation: Q Mod; X Polarization)
4	GND
5	BIAS Channel 6 (OIF Implementation: Q Mod; Y Polarization)
6	BIAS Channel 4 (OIF Implementation: Phase; Y Polarization)
7	BIAS Channel 1 (OIF Implementation: Phase; X Polarization)
8	GND

### 5.4.5 SCHEMATIC OF EXTENSION BOARD V1

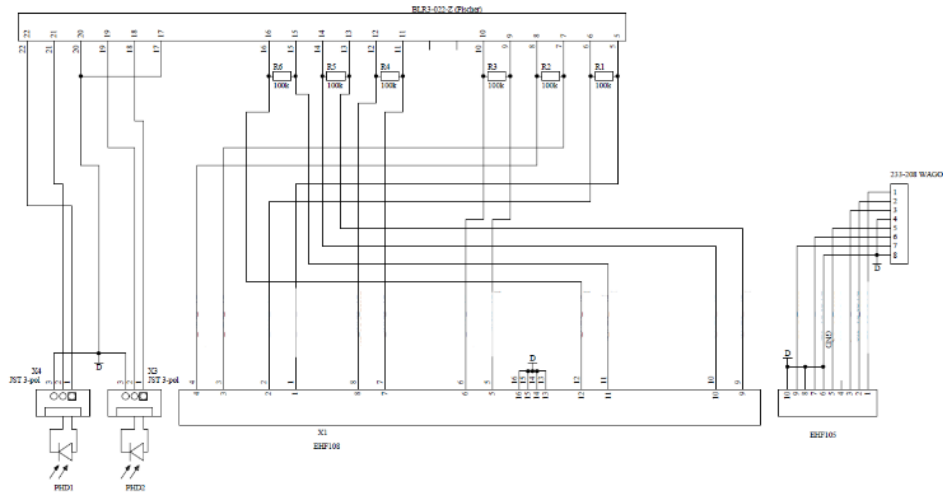



### 5.4.6 SCHEMATIC OF EXTENSION BOARD V2

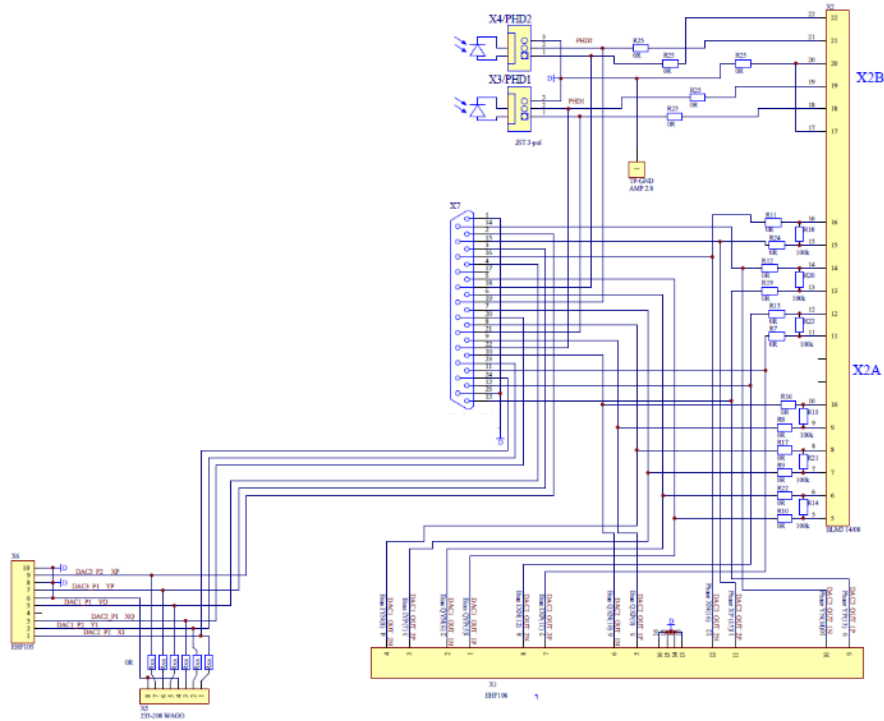

### 5.5 MAXIMUM BIAS RANGE

The maximum BIAS Voltage range can be limited from its hardware maximum continuously from 0V to maximum via Software to avoid damage to MZM H/W that may have a limit lower than what is supported by the ABC. Consult the data sheet of the connected MZM to obtain the corresponding Voltage usually found in the Maximum Rating section. Refer to the section “Software” for details setting this parameter via GUI or via remote control.

#### 5.5.1 DEFAULT CHANNEL ASSIGNMENT FOR DIFFERENT MZM CONFIGURATIONS

The following table summarizes the default channel assignment for different MZM control modes. Note that it is possible to alter this assignment by Software using the CHASS command. For details refer to the programming section.

CHANNEL #	DUALPOL IQ	SINGLEPOL IQ	DUALPOL I	SINGLEPOL I
1	XP	P	XI	I
2	XI	I	YI	-
3	XQ	Q	-	-
4	YP	-	-	-
5	YI	-	-	-
6	YQ	-	-	-



## 6 CONTROL LOOP

The ABC unit allows a number of configurations for various MZM configurations; see the table located in section 2.2 for an overview from application perspective. The control loop is configured either using the GUI or the SCPI command “mode”. This will set the ABC to find the target points per table below. For channel assignment depending on the mode, see chapter “Remote Control”.

### 6.1 CONTROL LOOP MODES

The acronym “IQ” refers to a nested MZM structure used for complex IQ modulation; see section 2.2 for details.

The acronym “II” refers to a single MZM used for intensity modulation as depicted in section 2.1.

In case of 2 Photodiode feedback, the unit adjusts to 2 feedback channels, one for each polarization.

In case of 1 Photodiode feedback and a Dual Polarization setup, the unit requires a single photodiode that taps the signal after the Polarization MUXing stage.

Possible modes are:

MODE <sup>3</sup>	GUI DESCRIPTION	NUMBER OF PHOTODIODES	NUMBER OF CHANNELS USED	MZM CONTROL TARGET <sup>4</sup>		
				PHASE	I	Q
1	DualPolIQ, 1PD	1	6	Quad	Min	Min
2	DualPolIQ, 2PD	2	6	Quad	Min	Min
3	SinglePolIQ, 1PD	1	3	Quad	Min	Min
4	Do not use	-		-	-	-
5	DualPolII, 1PD	1	2	-	Quad	-
6	DualPolII, 2PD	2	2	-	Quad	-
7	SinglePolII, 1PD	1	1	-	Quad	-
8	SinglePol I Min	1	1	-	Min	-
9	DualPol I Min,1PD	1	2	-	Min	-
10	DualPol I Min,2PD	2	2	-	Min	-

<sup>3</sup> Refer to chapter “Remote Control” for definition of the mode command.

<sup>4</sup> See section 2.1 for details on MZM transfer curve

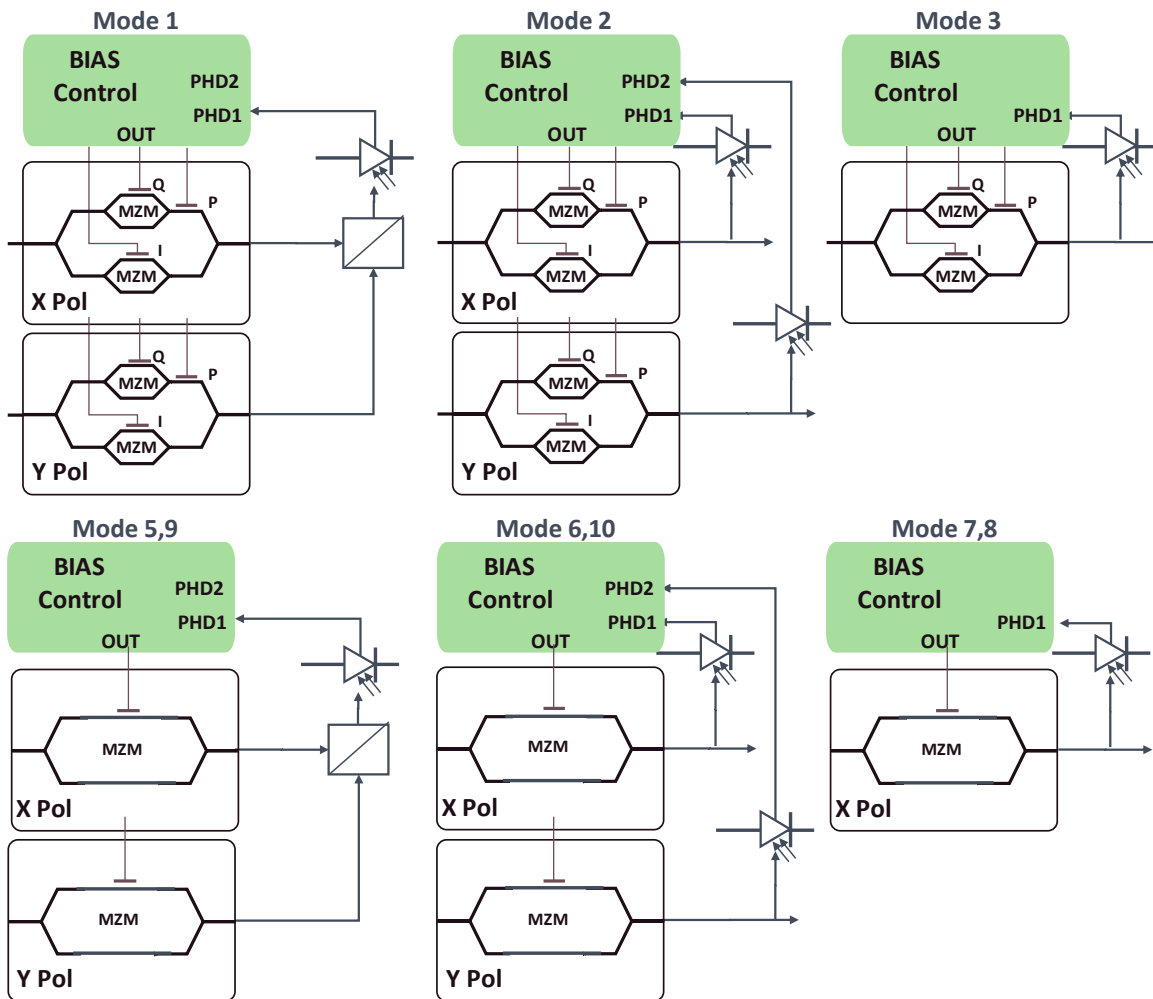

### 6.1.1 MULTIPLE SINGLE POL MZM WITH A SINGLE ABC

#### 6.1.1.1 SINGLE POL IQ MODULATOR

Up to 2 Modulators can be operated using a single ABC board. Configure a Dual Pol. IQ modulator and 2 Photodiodes for this case.

#### 6.1.1.2 SINGLE POL INTENSITY (II) MODULATOR

Up to 2 Modulators can be operated using a single ABC board. Configure a Dual Pol. II modulator and 2 Photodiodes for this case.

### 6.2 BIAS CONTROL LOOP STATE MACHINE

The ABC is based on a finite state machine model. It can assume the following states MANUAL, TRACKING, TRACKING\_PAUSE, INIT, INIT\_PAUSE and FAULT

Please see below a state diagram including all possible state transition conditions.



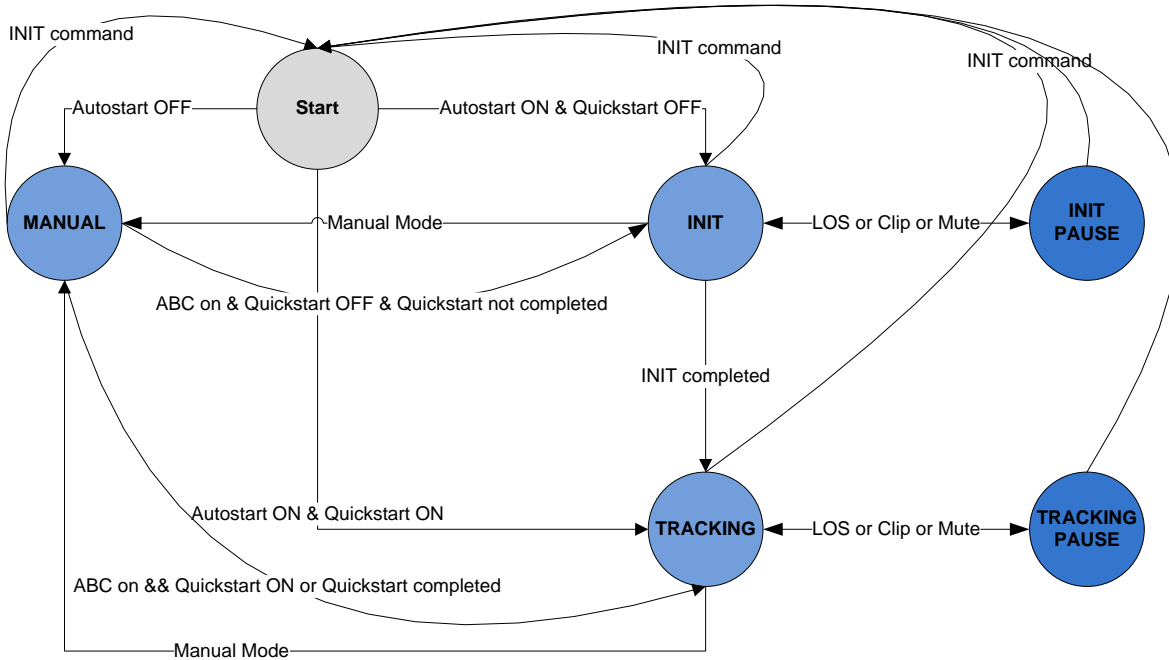

The ABC will find and track the optimal BIAS points in 3 phases:

1. INIT (if QuickStart is off): A coarse sweep of one or multiple BIAS electrodes is done.
2. TRACKING (not settled): The control loop runs in an accelerated tracking mode to swiftly move close to the target setting.
3. TRACKING (settled): The control loop runs in a slower tracking mode to achieve best accuracy and performance.

### 6.3 CONTROL LOOP OPTIMIZATION (FEEDBACK OFFSET)

The Offset feature can be used to tune the Automated BIAS Control to achieve an optimized operating point, i. e. to improve extinction of the MZM if the BIAS control finds a suboptimal point due to i. e. feedback detector issues. It can also be used so generate non-typical MZM BIAS settings. This feature applies to each channel separately; refer to the sections “Graphical User Interface” and “Remote Control” for details.

Note that there are limitations if offset values chosen too high as the steepness of the feedback curve drops relative to the nominal setting point. At first, accuracy of the control loop will suffer and gradually become unstable.

## 7 TROUBLESHOOTING AND VALIDATION

There are several scenarios that typically happen when connecting the unit to a setup. The following section describes typical issues and their fixes as well as some hints how to troubleshoot your setup.

### 7.1.1 GENERAL PROCEDURE

It is advisable to first test the ABC without RF modulation to be able separate issues. Use a power meter at the output of the MZM structure to validate if the unit moves close to the desired target point.

For any mode that moves the MZM to minimum transmission, the output power will naturally be minimized without RF modulation. As the ABC has a loss of signal feature (LOS), it might stop to continue to track and declare a LOS. In order to avoid that, enable the track in loss feature (GUI tab “ABC Config”) or SCPI command “`trilos 1`”. Make sure to disable the feature after completion of the test again.

For IQ structures, the inner MZM are moved to minimum transmission. Consequently, the output power should be minimal if the unit tracks properly. The phase electrodes are not tested by this scheme but typically, the issue is impacting all electrodes so that this is a good first test.

Similarly, there is no difference between a Single Polarization and Dual Polarization device. As long as the overall output power is minimized, it is a good indication that the setup is ok.

For Intensity MZMs, the output power depends on the target setting. For Quad mode, the output power should be 3dB less than the maximum transmission output power. This power can be easily determined by manually moving the BIAS point through the transfer curve.

For Min Mode, naturally, the output power should become minimal in a working feedback loop.

Besides a regular initialization and tracking sequence as described in the following section, another test can help to validate the proper operation of the feedback loop. Either move the unit manually to the target point or let the ABC do that (1).

Then, switch to manual mode and move one or more electrodes by 10-20% of VPI out of the setpoint (2). Enable the control loop again. If working properly, the unit settled indicator will turn off and you should see the control loop moving the electrodes that were offset back to the original value within a few seconds (3) and then declare settled again (4). The trace below shows are working device.

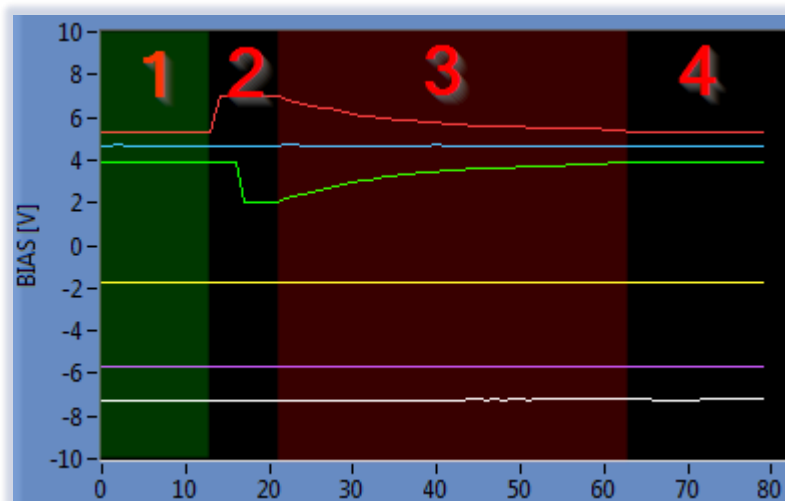

### 7.1.2 GOOD REFERENCE CASE

The following trace is a typical example for a regular tuning process for a DP IQ MZM. It is divided in 3 Phases.

1. Init Phase: The Phase electrodes of the IQ nested structure are swept
2. Fast Tuning Phase: The Phase electrodes are set to a good start value. The I&Q electrodes are moving fast toward the target values. As they approach it, the speed slows down. There may be a minor overshoot.



3. Tracking Phase: The settled indicator becomes green indicating that the unit is now in tracking phase. The update rate becomes smaller and, depending on MZM substrate material, the voltages will slowly drift over time as the ABC maintains the optimal operation point for the structure. There will be minimal further improvements of the setpoint over the first 2-3minutes of the phase.

In this example, the time to enter the tracking phase took ~35seconds. The gain of the control loop depends on the feedback level provided by the optics. This feedback level depends on the laser power at the MZM, the MZM insertion loss and the coupling ratio of the Photodiode tap coupler as well as the PD responsivity.

Since the gain may be different for your setup, the speed of convergence may differ a lot.

In this example, the Laser power was +14.5dBm, intrinsic insertion loss of the MZM 8dB, the photodiodes were coupled an unused port of an internal coupler structure (no extra loss).

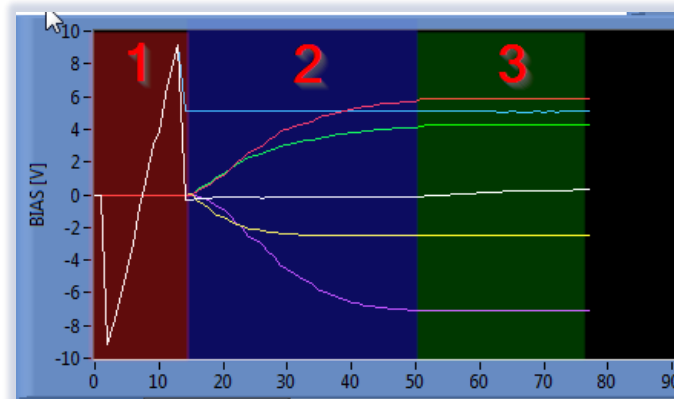

The shape of traces will look similar for other MZM structures.

### 7.1.3 MISSING OR VERY SMALL FEEDBACK

In case of missing feedback, a typical symptom is that the initial sweep is performed but then, there is virtually no move in the electrode voltages (a few Milli-Volts only) which gradually drift to the edge over a long period.

Note that in this case, the unit will declare “ABC Control loop settled” right after the init phase. This is because the unit cannot distinguish between a settled case and a missing feedback case.

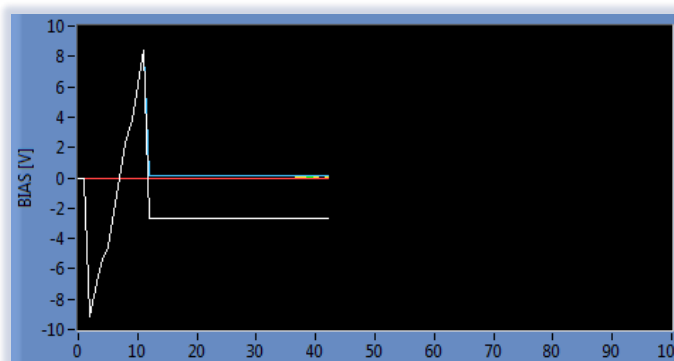

The root cause for this issue is a missing feedback signal.

Possible Reasons:

- The BIAS outputs are not connected or are not connected in the correct order. Switch to manual mode and try to manually move the structure to optimal point. This helps to validate that the wiring is ok. For MZM structures, validate that the channels are connected correctly. You can also rewire the outputs via S/W using the command “chass”. See remote section for details. Note that chass requires a “save current status” command to become permanent.
- The feedback photodiode(s) are not connected correctly. Check if the Percentage values in Tab “ABC Config” or the power readings change when BIAS settings are changed or when the laser power is changed. In case of 2 Feedback PDs check if they are connected in the right order. Channel PHD1 is used for X-Pol (channels 1-3), PHD2 for Y-Pol (channels 4-6).



- Check that the VPI Settings in Tab “ABC Config” are correct. Note that these are NOT the VPI values for the RF electrodes but for the BIAS electrodes. For LiNbO substrates, a typical value is 8V.

#### 7.1.4 CONTROL LOOP IS MOVING TO THE WRONG TARGET SETTING

The trace for such an issue looks very similar to the reference case. However, i. e. for an IQ Modulator, the control tracks a maximum transmission point instead of a minimum transmission case which can be detected using a power meter (see intro to this section). Similarly, for Intensity MZMs, the setpoint is the max. transmission instead of min transmission and negative instead of positive slope or vice versa for Quad setting.

Solution: Flip the feedback direction of the control loop using “Feedback direction” in Tab “ABC Config”. Note that for nested IQ structures, it is advisable to toggle the feedback sign for all electrodes and then run the init sequence as the feedback sign and current setting of each MZM in the structure influences the other MZMs as well causing cascading jumps of the sign between the MZM BIAS points.

#### 7.1.5 BIAS VOLTAGES ARE MOVING VERY SLOW TO TARGET POINT OR OSCILLATE

The root cause is that the gain of the feedback loop is either too small (slow movement) or too high (oscillations). The units’ parameters are set to be able to work with setups as wide as possible. However, for some setups, it might be required to adapt the feedback setting.

Use the command “ABCGain x” to change the gain factor of the feedback loop where x is a positive number  $>0$ . The default is 1, larger values will increase the gain and counteract too slow movements and smaller values will eliminate oscillations.

#### 7.1.6 QUICKSTART ON

QuickStart skips the init Phase (1), see above, and should only be used if the feedback loop is working properly and a good initial working point was saved before using save current status. The typical symptom is that the initial sweep is missing.

Solution: Disable QuickStart.

## 6 Web Interface (GUI)

The unit can be accessed by any devices such as smartphones, PCs etc. that are able to operate a web browser. The Web Interface was tested on Windows 7 and Windows 10 Computers using Edge, Chrome and Firefox and iPhone/iPad using Safari browser. Note that we cannot guarantee operation in any Browser environment in general.

If connected via USB, a virtual Ethernet interface is installed on the host system so that the Web Interface based access is enabled.

To access the unit, enter “abc.local” or the current IP address of the unit into the address field of the browser to open the GUI. Note that DNS resolution might not work on your host PC. See section 0 for details on that.

All fields provide a description of their usage by tooltips when hovering the mouse arrow on them. Therefore, this manual just highlights the basic features of the tabs and sections.

The top line contains status indicators such as Output power, feedback status, Alarm etc.

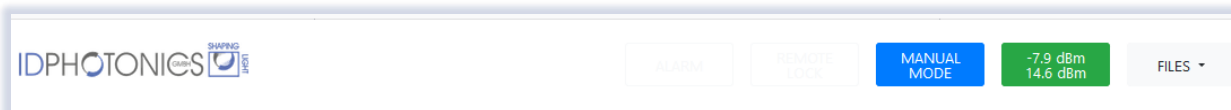

The Files Dropdown menu allows opening resources such as the manual related to the unit. These resources are stored locally in the unit.

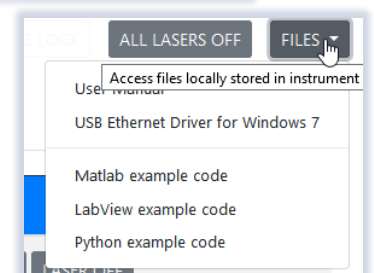



## 7.2 ABC CONTROL

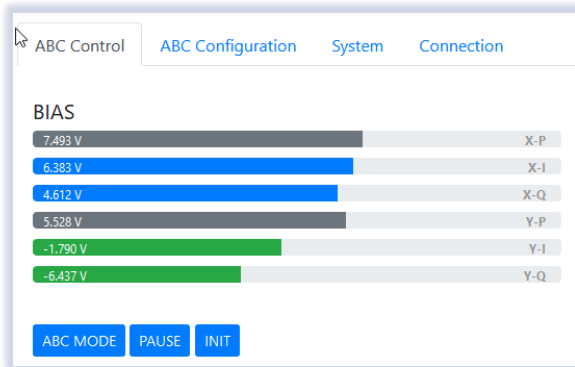

The ABC Control tab shows the current status of the output voltages. This reconfigures depending on the MZM structure to be controlled.

“**ABC Mode**” toggles between controlled mode and manual mode. In manual mode, click on the voltage bars to open a popup that allows to change the values.

## 7.3 ABC CONFIGURATION

This tab is used to configure the Control loop. Some fields may be grayed out which means they can currently not be changed. Make sure to elevate the user level to 1 (default PW IDP) and the control loop to be in manual mode to change these.

Note that some settings require to be saved via Save current status to be become permanent and be present after a INIT of the ABC.

“**ABC mode**” allows selecting the MZM configuration to be controlled by the unit

“**Display output range for port**” will change the voltage display of the GUI and SCPI queries depending on cabling of MZM to ABC unit. Make sure to check the VPI setting after this has changed as VPI is automatically scaled relative between this setting and previous setting.

“**Software max range**” allows to limit the available hardware output range to a smaller range for cases where MZM hardware maximum rating is smaller than range supported by the ABC and therefore protect the hardware

“**Tracking – active channels**” allows to switch individual channels into manual mode.

“**Tracking – Feedback direction**” allows to invert the sign of the ABC control loops for adaption to the specific connection of user hardware to ABC unit defaults. See chapter troubleshooting for details.

“**Tracking – Feedback Offset**”: The corresponding channel the control loop for will be offset by the value entered here. The sign of offset values can be positive or negative. Depending on the sign of the value entered, the control loop will shift the settled point to the corresponding directing.

Typical offset values would be  $1e+5$  to  $1e+6$ . We recommend starting with a small value while the control loop is active and observe the impact on the settling point. Slowly start to increase the value until the control loop tracks the desired value. If it moves in the wrong direction, invert the sign of the offset value. Note that the control loop will become unstable if high values are entered. ID Photonics can take no liability on effective operation of the unit if these values are non-zero and recommend leaving all values at 0.

Note that the values are set are stored in volatile memory only. Thus, each reset of the unit will also reset the offset values. In order to store them permanently, use the “**save current status**” button to save the values set.

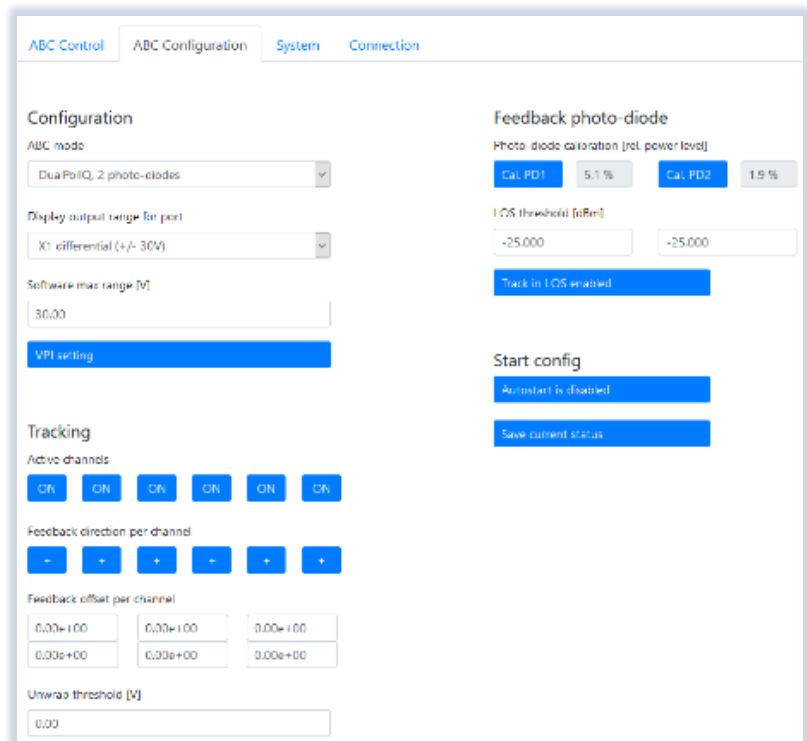



“**Feedback Photodiode**” displays the DC level photocurrent at detector in percent of maximum value if no calibration has yet been performed. There is internal gain switching so that the value is not linear across all powers present at the feedback photodiode. If “**Cal PDx**” is pressed, a popup is opened. Enter the current optical power present at the feedback monitor measured with an external Optical Power Meter. After the value was entered, the values will switch to “dBm”. For benchtop units with integrated photodiode feedback receiver, this has been calibrated during manufacturing process already. The number of displayed photodiodes depends on the “**ABC mode**” setting. In case of 2 integrated photodiodes used in a MZM, it may not be possible to properly calibrate the optical power of each PD as the port is physically inaccessible.

“**Unwrap threshold**”

“**LOS threshold**” is the value below which the ABC pauses tracking since no feedback value can be generated. This feature is only used if the photodiode power has been calibrated before per above description. The number of displayed values depends on the “**ABC mode**” setting.

“**Autostart**” will en- or disable the automatic start of the ABC loops upon startup of the ABC unit.

“**Save Current Status**” will save the current status such as current BIAS values of the ABC that will be used upon next init or restart of the ABC unit. See section 8.10.2 “parameters stored by SCSTAT” for details on which parameters are stored by this action.

“**Unwrap threshold**”: The ABC will try to track the BIAS point to the limits of its output range. In order to avoid that tracking becomes impossible because the limit is reached. Setting a nonzero value will unwind the current setting to the next period of the MZM transfer curve and continue to track there if the set difference between the minimum or maximum available range and the set threshold is exceeded. Note that there will be a transitory time when the switching occurs. For a setting of 0V, the feature is disabled.

## 7.4 SYSTEM

This tab gives information about alarms, allows Firmware updates, sending SCPI commands defined in the remote section of this manual and restarting the unit. See tooltips for details on the individual displays.

The screenshot shows the 'System' tab of the ABC Control interface. It is divided into four main sections:

- Alarm details:** Lists various alarm types such as 'BIAS value at limit', 'Init error', 'Feedback signal warning', 'Gain error, feedback signal too low or too large', 'Hardware error', 'DC signal warning', 'Input Signal warning PHD1', 'Input Signal warning PHD2', 'Start Init search failed', and 'FB failure'. A 'Clear latched alarms' button is located at the bottom of this section.
- Device management:** Contains two buttons: 'Restart unit' and 'Shut down unit'.
- Start configuration:** Contains one button: 'Start with factory defaults'.
- Firmware update:** Includes a 'Select update package:' dropdown menu with 'Durchsuchen...' and 'Keine Da...ewählt.' options, and an 'Update firmware' button.
- SCPI control:** Features a 'Send command:' label, a text input field containing '\*idn?', and an 'Abort pending commands' button.



ABC Control ABC Configuration System Connection

**Network settings**

DHCP  
DHCP is disabled

IP address  
192.168.0.1

Netmask  
255.255.255.0

Gateway IP  
192.168.0.255

DNS1 IP  
192.168.0.255

DNS2 IP  
192.168.0.255

MAC-Address  
44:B4:12:03:1C:A5

USB IP address  
169.254.7.232

Reset network settings to defaults

**Device info**  
Idn: IDP ABC-BPC-11-x, SN 20440099, F/W Ver 2.1.0(9999), HW Ver 1.10(502)

Download service logs

**Connection status**  
●

**User level authentication**  
Password  
..... Logout

## 7.5 CONNECTION

This Tab provides info on the device such as Part/Serial Number, Hardware and installed Firmware revision. It also allows to change the IP Configuration of the network interfaces of the device.

“**Download service logs**” will collect debug information of the system in case of issues. Allow up to 2 minutes to finish the collection, save the binary data to the host PC and send it to ID Photonics for troubleshooting. The files are not user viewable.

“**User level authentication**” allows entering a password to elevate the session user level rights which will enable buttons and fields currently disabled. For details, see remote section 8.4.

“**Connection status**” indicates active communication between the unit and the browser session. The blue dot will morph its size when communication is active.

“**Network settings**” display the current settings of Ethernet ports installed in the unit. The view may look different depending on the type of device being used.



## 8 REMOTE CONTROL

This device operates using SCPI standard style commands which are ASCII based and allow easy communication and interpretation with the instrument. Refer to chapter “Board and Connector description” on how to establish communication to the ports available at the instrument. More detailed information on SCPI syntax can be found here: <http://www.ivifoundation.org/docs/SCPI-99.PDF>

### 8.1 OPERATING MULTIPLE INTERFACE PORTS

This unit supports parallel usage of all remote-control ports available. Note that responses to commands issued are only returned to the according interface from where the command was issued.

Commands are generally executed in order of time wise arrival to the controller and buffered into an Event queue. If a stack overflow occurs, an error is issued.

Note that there is no control exclusivity for a specific interface or user. Thus, parallel commands issued by different instances will be might lead to inconsistencies. It is therefore recommended to poll current parameter status to ensure integrity of set vs. actual parameters and query the operation complete register (“\*opc?”) to make sure all previous commands have been executed or applied to the laser control. Note that it is recommend to use the query “busy?” to determine if a laser port is still tuning as the “\*opc?” query will only tell if the corresponding change of configuration has been triggered but might not be completed.

### 8.2 QUERY CONNECTION TYPES

Connections to remote control the unit via SCPI can be made either by using telnet protocol on port 2000 or HTTP queries. While for performance reasons, telnet-based access should be preferred, HTTP based access can be used in installations where Port 2000 is blocked by Network firewalls or routers since HTTP uses Port 80 which is open in most networks.

#### 8.2.1 TELNET BASED

Connections made with the device can be session based by a raw terminal connection (see 4.1.2) using Port 2000 for Ethernet or a COM Port session (see 4.2.1.3).

Connections through HTTP Service (Port 80). In this case, the SCPI command is encapsulated in the following http request:

```
http://<ABC IP>/scpi/<SCPI-Command>
```

#### 8.2.2 HTTP BASED

Example: [http://abc.local/scpi/\\*idn?](http://abc.local/scpi/*idn?) queries the identification string of the unit. For a quick test, simply copy this query into the browser address field.

The ASCII encoded response is identical to the session-based response.

<wsp> characters defined in the SCPI definitions are to be replaced with ASCII string “%20” per HTML code standard requirements. No termination character “;” or <CR> is needed for HTTP based access.

Multiple commands can be sent within a single query by means of separation via the termination character “;”

Example: [http://abc.local/scpi/\\*idn?;lay?](http://abc.local/scpi/*idn?;lay?)

Note that this connection type is not session based like the terminal connection. So, each query sent will establish a new session which is terminated after the query response is given. Consequently, commands requiring elevated user rights will require to send the password with the actual query in the same request.

Example: <http://abc.local/scpi/pass%20IDP;pass?> will send the password “IDP” to the unit to elevate the user level.





## 8.3 SYNTAX CONVENTIONS FOR COMMANDS

### 8.3.1 LONG AND SHORT FORM

The key words feature a long form and a short form. Either the short form or the long form can be entered in one command, other abbreviations are not permissible.

Example: “:SYStem:IPADDRess?” is equal to “IPADDR?”

#### ! NOTE

The short form is marked by upper-case letters; the long form corresponds to the full expression. Upper-case and lower-case notation only serve the above purpose, the instrument itself accept both upper-case and lowercase letters.

#### ! NOTE

All commands are case insensitive. Long and short form may not be mixed within a single command.

### 8.3.2 QUERY COMMANDS

Most commands serve a double function that allows either setting or executing a query on a parameter.

#### ! NOTE

Query commands are terminated by a “?” character.

### 8.3.3 PARAMETER

Parameters must be separated from the header by a “white space”. If several parameters are specified in a command they are separated by a comma “,”.

### 8.3.4 COLON CHARACTER

A leading colon character “:” instructs the instrument to interpret the command starting at the root (highest level) of the command tree. Since the Instrument also starts at the root each time you send it a new command, the leading colon is not required (although the instrument will accept it if you send it).

### 8.3.5 COMMAND TERMINATION CHARACTER

Each command must be terminated either by a “;” character or a carriage return (ASCII #13) to signal completion of the command telegram to the controller.

#### ! NOTE

Sending two termination characters is a common mistake causing the unit to respond with “ERR 100;” since the first command is executed once the first termination character is received and the second termination character causes the unit to interpret an empty command. Example:

Command: “mode 1;<CR>”

Response “;<CR>ERR 100, unknown command;”

The unit will set wavelength 1550nm to port 1,1,1 but additionally receives the empty command which causes the error response.

### 8.3.6 ACKNOWLEDGEMENT OF EXECUTED COMMANDS

The mainframe controller will always acknowledge successful execution of commands by a “;” character. If the echo option is set (for details, see command list), the accordingly sent command is returned first.

### 8.3.7 COMMUNICATION EXAMPLE

Host sends: \*idn?;



unit response: IDP-ABC-BPC-11-x, SN 19160001, F/W Ver 1.0.0(101), HW Ver 1.10(502);

### 8.3.8 BASIC SCRIPT EXAMPLE

The following commands can be a minimal script to perform a basic set up of the unit and read the data

COMMAND	COMMENT
*IDN?;	Query idn string of unit
PASS IDP;	Raise user level to 1
VOLT?;	Get current BIAS Voltages
*opc?;	Queries if command has been executed (status 1).

Screenshot of script example result:

```

192.168.0.1 - PuTTY
*idn?
IDP ABC-BPC-11-x, SN 20440099, F/W Ver 2.1.0(9999), HW Ver 1.10(502);
pass IDP
;
volt?
7.493,6.383,4.612,5.528,-1.790,-6.437;
*opc?
1;

```

<ENTER> was used to execute the command. Alternatively, use “;”. If both termination characters are used, it is interpreted as 2 commands of which the second one is empty so that the first command is executed but the second produces an error since empty.

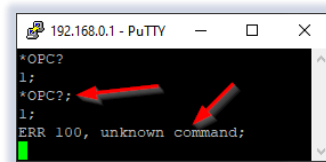

### 8.4 USER ACCESS LEVEL

This feature allows execution of commands protected in standard access level to avoid accidental change of important parameters. See command description “[ :SYStem: ] PASSword” for details on how to enable enhanced access.

Custom passwords can be set to the unit for enhanced security requirements. See details in description for “[ :SYStem: ] SetPASS<wsp>, <P>, <P>”.

#### ! NOTE

User access level is granted session based. Each time, a new remote connection is made; the standard User access level 0 is set per default.

USER ACCESS LEVEL	PASSWORD
0	-
1	IDP



## 8.5 NOTATION OF SYNTAX FOR COMMAND DEFINITION

SYNTAX AND TYPE	DESCRIPTION
[ ]	Optional command level that can be omitted. Example: Definition [:SYStem:]IPADDRess/? /<P> Allows sending the command: IDADDR?
< >	Denotes a parameter. Placeholder is replaced with parameter value defined for according command. Definition [:SYStem:]IPADDRess/? /<P> Allows setting the parameters: [:SYStem:]IPADDRess 192.168.0.1
/?	Denotes the optional character “?” that is used if the command can also be used as a query. Example: Definition [:SYStem:]IPADDRess/? /<P> “?” is used to query current IP Address of the device: IPADDR?;
:	Usage of Colon see 8.3.4
<wsp>	Denominates a white space character
<INT>	Integer value
<REAL>	Real value

## 8.6 GENERAL SCPI COMMANDS

SYNTAX	EXAMPLE	DESCRIPTION
*idn?	*idn?; IDP ABC-BPC-11-x, SN 20440099, F/W Ver 2.1.0(9999), HW Ver 1.10(502);	Query System Type and Software version.
*opc?	*opc?; 1;”	Query if all pending commands were executed. Note that this will NOT indicate if physical tuning of laser ports has been completed. Use busy? Query for this.
*rst	*rst;	Reset Controller; will warm start the instrument. All connections/sessions will be closed. Requires user level 1
*WAIt	*WAI; ;	Unit waits with response until *opc? is 1. Eliminates need for polling loop of *opc? on remote side
*CLS	*CLS; ;	Clears all status/alarm registers of the unit. This command is used to clear latched alarm registers.

## 8.7 CHANNEL ASSIGNMENT INDEX TO BIAS ELECTRODE TYPE FOR SCPI

Channels assignment in SCPI commands are coded in integer numbers. Refer to the table below to determine assignment of Channel ID to electrode type.

The assignment can be changed in software using the command CHASS

CHANNEL #	DUALPOL IQ	SINGLEPOL IQ	DUALPOL I	SINGLEPOL I	CUSTOM
1	XP	P	XI	I	1



2	XI	I	YI		2
3	XQ	Q			3
4	YP				4
5	YI				5
6	YQ				6

## 8.8 NOTATION OF SYNTAX FOR COMMAND DEFINITION

SYNTAX AND TYPE	DESCRIPTION
[ ]	Optional command level that can be omitted. Example: Definition [ :SYStem:] IPADDRess/? /<P> Allows sending the command: IDADDR?
< >	Denotes a parameter. Placeholder is replaced with parameter value defined for according command. Definition [ :SYStem:] IPADDRess/? /<P> Allows setting the parameters: [ :SYStem:] IPADDRess 192.168.0.1
/?	Denotes the optional character “?” that is used if the command can also be used as a query. Example: Definition [ :SYStem:] IPADDRess/? /<P> “?” is used to query current IP Address of the device: IPADDR?;
:	Usage of Colon see 8.3.4

### 8.8.1 CONVENTIONS FOR WRITING TO MULTI-CHANNEL OUTPUTS

For read queries issued to a Multi-Channel output such as the BIAS Electrodes, the interpreter will return the current setting of all channels available, i.e.:

Query VOLT?;

Response: 2.34, -5, 6.98, 3.1, 9.99, 12.93;

For Write Commands, each channel must be set separately by a command. The following example sets the BIAS Voltage for channel 2 to 5.67V:

Command VOLT 2, 5.67

Response: ;

## 8.9 COMMANDS ON SYSTEM LEVEL

SYNTAX	READ WRITE	USER ACCESS LEVEL	PARAMET ER FORMAT	DESCRIPTION
[ :SYStem:] ECHO/? /<w sp><P>	RW	0	“0” or “1”	Sets or query echo command sent status, this setting applies to current session only
[ :SYStem:] DHCP/? /<w sp><P>	RW	1	“off” or “on”	configure DHCP Setting for Ethernet interface
[ :SYStem:] IPADDRess /? /<wsp><P>	RW	1	xxx.xxx.xxx.x xx	IP Address Setting of Ethernet interface
[ :SYStem:] NETMASK/? /<wsp><P>	RW	1	xxx.xxx.xxx.x xx	Netmask Setting of Ethernet interface



SYNTAX	READ WRITE	USER ACCESS LEVEL	PARAMET ER FORMAT	DESCRIPTION
[ :SYStem:] GATEWAYIP /?/<wsp><P>	RW	1	xxx.xxx.xxx.x xx	IP address for Gateway of Ethernet interface
[ :SYStem:] USBIPADDR ess?	R	0	xxx.xxx.xxx.x xx	IP Address Setting of virtual Ethernet interface on USB
[ :SYStem:] USBNETMAS K?	R	0	xxx.xxx.xxx.x xx	Netmask Setting of virtual Ethernet interface on USB
[ :SYStem:] MACADDRESS?	R	0	XX:XX:XX:XX: XX:XX	Reads MAC Address of unit
[ :SYStem:] IPConfigD EFault	W	1	-	Resets all settings of remote interfaces to factory defaults. This becomes effective only after a reboot of the unit.
[ :SYStem:] INTerface Init	W	0	-	Reset session parameters to defaults. Call this after opening the remote port. This command resets ECHO, PASS, FORMAT, UNIT:X, LINLOG, EVENT.
[ :SYStem:] REMOte?	R	0	"0" or "1"	Query remote status of device. Any open remote sessions via Ethernet?
[ :SYStem:] PASSword/ ?/<wsp><P>	RW	0	ASCII	Set new User level status by sending password or query current User level status
[ :SYStem:] TIME?/ <wsp><P>	R/(W)	0	xxxxxxxx	Query or set system time. Note that time is set and tracked in volatile memory only. It requires to be set after each cold start.
[ :SYStem:] ALARm?	R	0	xxxxx	Query alarm status of device, see Alarm code definition for details
[ :SYStem:] ERRor[:NE XT]?	R		-	Queries data in an error queue and deletes it from the queue.
[ :SYStem:COMMunicat e:] LOCKout/?	RW	1	"0" or "1"	Locks other sessions to perform write commands on the unit. It is automatically released if the active session closes
[ :SYStem:COMMunicat e:] ParameterREFresh ?	R	0	<INT>	This query allows detecting if any change to the configuration was done. Each time the counter increases, the configuration was changed. This is useful in multi-user environments to detect if a parallel session has changed settings on the unit
[ :SYStem:] IPConfCha nged?	R	0	0 1	Check if IP configuration of the Ethernet Interface was changed but no reboot was triggered yet to activate the new settings. This can be used to determine if the actual settings differ from the settings that will be active upon restart.



SYNTAX	READ WRITE	USER ACCESS LEVEL	PARAMETER FORMAT	DESCRIPTION
[ :STATus:OPERation: ]EVENT?	R	0	-	Read status of instrument if scan has been completed (1) or not (0). Each read of "EVENT?" will clear the status for each remote session separately. This can be used to query if previous scan has been completed.
[ : ]ABORT	W	0	-	Aborts all currently executed pending commands as fast as possible. Query *OPC? To determine status once all pending commands are aborted
[ :BOOT: ]BootLoaDerRESet	W	0	-	Resets upload procedure for firmware upgrade. All data uploaded already is erased. New process can be restarted
[ :BOOT: ]BootLoaDerAPPend	W	0	binary	send portions of the binary Firmware Image, each Byte is coded into 2 Characters 1..F, send max. 100 Bytes per command
[ :BOOT: ]BootLoaDerEXECute/?	RW	0	-	Set: Executes upgrade of previously uploaded Firmware image. Query responds with current status of execution.
[ :SYSTEM: ]ENableLOGging/?	RW	R 0 W 1	"0" or "1"	This command enables local logging in the unit that can be used for debugging purposes. Enable this only if a persistent issue exists and ID Photonics asked you to enable the feature since this can slow down the performance of the instrument. The trace file read via RDEBUG is encrypted and cannot be checked by the user.
[ :SYSTEM: ]ReadDEBUG	R	0	-	Collects debug information from OSA which can be sent to ID Photonics for troubleshooting. Returns a maximum of 1000bytes per read. Responds "WAIT" as long as debug data is still collected. Responds "EOL" if all data is read.
:SYSTEM:RESet	W	1	-	Will reset instrument. Same as command *rst, see details in description of *rst
[ :SYSTEM: ]SetPASS<w sp>, <P>, <P>	W	-	-	Sets a password to access the defined user level. Requires current user level to be at or higher for level that password is to be set. First parameter is user level for which password is set, second is a string defining the password.
[ :SYSTEM: ]OUTputRANGeSelect? /<P>	RW	1	0, 1, 2, 3	Scaling of output BIAS values in VOLT command 0: X5 (0 - +5V) 1: X1 single-ended (+/-15V) 2: X1 differential (+/-30V). 3: X5 (+/- 5V)



SYNTAX	READ WRITE	USER ACCESS LEVEL	PARAMET ER FORMAT	DESCRIPTION
				Note that VPI values are scaled as well if this switch is changed.

### 8.9.1 COMMAND PROPERTY OVERVIEW

Session based parameters/commands will be initialized to default each time a new connection/session is opened to the instrument.

SYNTAX	READ WRITE	USER ACCESS LEVEL	SESSION BASED	DEFAULT VALUE
[ :SYSTem:]ECHO/?/<wsp><P>	RW	0	X	0
[ :SYSTem:]DEFAULT	W		-	-
[ :SYSTem:]INFORMatiOn?	R	0	-	-
[ :SYSTem:]DHCP/?/<wsp><P>	RW	1	-	OFF
[ :SYSTem:]IPADDRESS/?/<wsp><P>	RW	1	-	192.168.0.1
[ :SYSTem:]NETMASK/?/<wsp><P>	RW	1	-	255.255.255.0
[ :SYSTem:]GATEWAYIP/?/<wsp><P>	RW	1	-	192.168.0.255
[ :SYSTem:]MACADDRESS?	R	0	-	-
[ :SYSTem:]IPConfigDEFault	W	1	-	-
[ :SYSTem:]INTerfaceInit	W	0	-	-
[ :SYSTem:]REMote?	R	0	-	-
[ :SYSTem:]PASSword/?/<wsp><P>	RW	0	X	-
[ :SYSTem:]TIME? /<wsp><P>	R/(W)	0	-	-
[ :SYSTem:]ALARm?	R	0	-	-
[ :SYSTem:]STATus?	R	0	-	-
[ :SYSTem:]ERRor[:NEXT]?	R		-	-
[ :SYSTem:COMMunicate:]LOCKout/?	RW	1	-	0
[ :SYSTem:COMMunicate:]Parameter REFresh?	R	0	-	0
[ :STATus:OPERation:]EVENT?	R	0	-	-
[ :]ABORT	W	0	-	-
[ :BOOT:]BootLoaDerRESet	W	0	-	-
[ :BOOT:] BootLoaDerAPPend	W	0	-	-
[ :BOOT:]BootLoaDerEXECute/?	RW	0	-	-
[ :SYSTem:]ENableLOGging/?	RW	1	-	0
[ :SYSTem:]ReadDEBUG	R	0	-	-



SYNTAX	READ WRITE	USER ACCESS LEVEL	SESSION BASED	DEFAULT VALUE
[ :SYStem:] IDENTify<wsp><P>	W	0	-	0
[ :SYStem:] ENABleAUTOSTart/?<wsp> /<P>	RW	1	-	0
[ :SYStem:] STArtDEFault /?<wsp> /<P>	RW	1	-	1
[ :SYStem:] SetPASS<wsp>, <P>, <P>	W	-	-	1
[ :SYStem:] OUTputRANGeSelect? /<P>	RW	1	-	1

## 8.10 BIAS CONTROL COMMANDS

### 8.10.1 COMMAND DESCRIPTION

COMMAND	PARAMETER OPTIONS	DESCRIPTION
[ :BIAS:] MODE/?	"1" to "8"	Set or query current MZM configuration. 1=DPIQ(1), 2=DPIQ(2), 3=SPIQ(1), 5=DPII(1), 6=DPII(2), 7=SPII(1), 8=custom; Number in brackets denotes the number of feedback photodiodes. See chapter "Control loop" for details.
[ :BIAS:] AUTOSTart/? /<P>	"0" or "1"	0: Bias Control will remain in Manual mode after startup 1: Bias Control will automatically run INIT and continue in TRACKING state
[ :BIAS:] QuickSTArt/? /<P>	"0", "1", "2"	Skips INIT state after startup. This option is only recommended if a settled state was saved previously via SCSTAT command. States 1 and 2 are identical.
[ :BIAS:] FACToryDEFault	-	Resets all parameters saved by SCSTAT back to Factory defaults.
[ :BIAS:] SETTled? /<P>	"0" or "1"	Indicates if Automatic BIAS Control is settled (only TRACKING mode)
[ :BIAS:] VPI/? /<P>, /<P>	x,x.xxx	Query or set VPI of BIAS Electrodes. Note: Changing these parameters will impact the performance of the automated control loop. See 8.8.1 for details on the parameter convention.
[ :BIAS:] INIT/?	"0" or "1"	Write: Will trigger the initialization routine Read: Indicates whether control loop is currently in initialization phase. 1: Init active 0: No Init in progress





COMMAND	PARAMETER OPTIONS	DESCRIPTION
[ :BIAS:]VOLTage/? /<P>, /<P>	-	Write: Set BIAS Voltages. First Parameter is Channel ID, second is BIAS Voltage to be set to selected electrode. Set is only possible in manual mode. See according table for electrode type assignment. Example: VOLT 1, 5.365; Read: Query current BIAS voltages. Response will be all 6 BIAS Voltages without Channel ID. Example: VOLT?; 1.987, 5.365,8.487,6.456,11.567,15.734; See 8.8.1 for details on the parameter convention.
[ :BIAS:]STAtusVOLTage? /<P>	"0" or "1"	Query if any BIAS Voltage is 5% or less to maximum/minimum
[ :BIAS:]CONTRol/? /<P>	"0" or "1"	Query or set status of automated BIAS Control. 1: Control Active 0: Manual Mode Active
[ :BIAS:]OPOWer? /<P>	+/-x.xx	Query current optical output power in [dBm]. For ABC only: This value is only correct if power calibration was performed before. The optional parameter allows to read only 1 channel. i.e. OPow? 1; reads the optical power of feedback channel 1
[ :BIAS:]MONPower? /<P>	+/-x.xx	Query current DC feedback level. Note that the unit uses an automated gain switch so that this value cannot be used as a power monitor. The optional parameter allows to read only 1 channel. i.e. OPow? 1; reads the optical power of feedback channel 1
[ :BIAS:]MUTE/? /<P>	"0" or "1"	Query or set MUTE status. If MUTE is active, automated BIAS Control will not change any BIAS Voltage and switch to a low noise mode intended for delicate measurements. A query will also indicate the MUTE status that is set by the external H/W input. 1: Mute Active 0: Standard operation
[ :BIAS:]LOSStatus? /<P>	"0" or "1"	"Query if output power of device is too low for automatic BIAS Control. 1: Loss of Signal (LOS) - Signal too low. Control loops stops 0: Signal within valid range" Note that this feature requires a valid power calibration of the feedback path.
[ :SYSTEM:]LOSThresh/? /<P>, /<P>	Ch, Power[dBm]	This sets the Loss of Signal (LOS) threshold of the unit. If the power at the feedback path drops below



COMMAND	PARAMETER OPTIONS	DESCRIPTION
		the specified value, the ABC stops tracking and a warning is issued. Note that this feature requires a valid power calibration of the feedback path.
[ :BIAS:] INitPROGress?	xxx	Progress of Init Procedure reported in [%]
[ :BIAS:] MAXRange/? /<P>	xx.xx	Query or set maximum Voltage applied to BIAS electrodes in [Volts]. Setting is possible only with User Access level 1 or higher and in MANUAL mode of BIAS control. This value can be between 0V and 48V.
[ :BIAS:] HWMAXRange?	xx.xx	Query or set Voltage setting of HARDWARE. This is the maximum Voltage range addressable by the hardware in [Volts]. This value can be 12,24 or 48V. This value is automatically set by the S/W, following HWMAXRange > MAXRange.
[BIAS:] TRackInLOS/? /<P>	"0" or "1"	If enabled(1), control loop is forced to continue operating even if LOS alarm is present. CAUTION: The control loop will drift away if no feedback signal is present (i.e. no photodiode connected).
[ :BIAS:] FOFFset/? /<P>, /<P>	x,x.xxx	Write: Set Feedback Offset target. First Parameter is Channel ID, second is offset of Feedback signal to selected electrode. See according table for electrode type assignment. Read: Query current offset value. Response will be all 6 Feedback offsets without Channel ID. Example: FOFF?; 1.987, 5.365,8.487,6.456,11.567,15.734; See 8.8.1 for details on the parameter convention.
[ :BIAS:] FeedBackDIRection/? /<P>, /<P>	1 to 6, "-1" or "1"	Write: Sets direction of Feedback signal control loop. First Parameter is channel #, second is direction +/-1. Read: Query control loop direction. Response will be 6 Feedback directions without Channel ID. Example: FBDIR?;  1, -1, 1, 1, 1, 1 See 8.8.1 for details on the parameter convention.
[ :BIAS:] CHannelACTIVE/? /<P>, /<P>	1 to 6, "0" or "1"	Write: Set control loop for selected channel to active/inactive Read: Query Control loop for channel active/inactive Write: Set control loop for selected channel to active/inactive Example: CHACT?; 1, 0, 1, 0, 1, 1



COMMAND	PARAMETER OPTIONS	DESCRIPTION
		See 8.8.1 for details on the parameter convention.
[ :BIAS:]CHannelASSign/? /<P>, /<P>	1 to 6, 1 to 6	Write: Will set control loop channel assignment to different H/W Channel Read: Assignment of control loop channel to H/W channel Example: CHASS 1, 4; Will assign logical output 1 to Hardware channel 4, logical output 1 is then left unused (0) CHASS?; Will be 0, 2, 3, 1, 4, 5; See 8.8.1 for details on the parameter convention.
[ :BIAS:]ABCGain/? /<P>	>0 Default: 1	This sets or queries a user gain adjustment factor of the feedback control loop.

### 8.10.2 COMMAND PROPERTY OVERVIEW

COMMAND	READ WRITE	SET IN MANUAL MODE ONLY	USER ACCESS LEVEL	STORED BY SCSTAT
[ :BIAS:]MODE/?	RW	X		
[ :BIAS:]AUTOStart/? /<P>	RW	-	0	X
[ :BIAS:]QuickSTART/? /<P>	RW	-	0	X
[ :BIAS:]FACToryDEFault	W	X	1	-
[ :BIAS:]SETTled? /<P>	R	-	0	-
[ :BIAS:]VPI/? /<P>, /<P>	RW	X	1	X
[ :BIAS:]INIT/?	RW	-	0	-
[ :BIAS:]VOLTage/? /<P>, /<P>	RW	X	0	X
[ :BIAS:]STAtusVOLTage? /<P>	R	-	0	-
[ :BIAS:]CONTRol/? /<P>	RW	-	0	-
[ :BIAS:]OPower? /<P>	R	-	0	-
[ :BIAS:]MONPower? /<P>	R	-	0	-
[ :BIAS:]MUTE/? /<P>	RW	-	0	-
[ :BIAS:]LOSStatus? /<P>	R	-	0	-
[ :SYSTEM:]LOSThresh/? /<P>, /<P>	RW	-	0;1	-
[ :BIAS:]INitPROGress?	R	-	0	-
[ :BIAS:]MAXRange/? /<P>	RW	X	1	X



COMMAND	READ WRITE	SET IN MANUAL MODE ONLY	USER ACCESS LEVEL	STORED BY SCSTAT
[ :BIAS: ]HWMAXRange?	R	-	1	X
[BIAS:]TRackInLOS/? /<P>	RW	-	1	-
[ :BIAS: ]FOFFset/? /<P>, /<P>	RW	X	1	X
[ :BIAS: ]FeedBackDIrection/? /<P>, /<P>	RW	X	1	X
[ :BIAS: ]CHannelACTive/? /<P>, /<P>	RW	X	1	X
[ :BIAS: ]CHannelASSign/? /<P>, /<P>	RW	X	1	X

### 8.11 SCPI CODE ERROR DEFINITION

ERROR #	DESCRIPTION
100	Command Syntax Command error
101	Parameter out of range
102	No data in buffer
103	device not ready
104	user level for this command not sufficient
200	Command execution error
201	user level rights to execute this command not sufficient, increase using PASS command
250	
251	
252	

### 8.12 ALARM CODE DEFINITION

BIT #	ALARM	CONDITION/DESCRIPTION
0	BIAS Value at limit	current Voltage <5% or 95% of avail range
1	Init error	An error occurred during init process
2	Feedback signal warning	feedback signal invalid
3	Gain error, feedback signal too low or too large	feedback signal too small or too large
4	generic Fault	general error
5	H/W error	Hardware error
6	Unused	-



BIT #	ALARM	CONDITION/DESCRIPTION
7	DC signal warning	Photocurrent out of range warning, <5% or 95% of avail range; only if no LOS present. Control will continue to operate if warning is present (unless LOS is present as well)
8	PD1 clipping error	Input Signal warning PHDx. The feedback photodiode current saturates the electronic circuit. Change the gain using SW3 as described in section "Board and Connector description". The control will pause as long as error is present.
9	PD2 clipping error	
10	Start Init search failed	Start Init search failed due to i. e. Clipping of input signals or improper feedback signal. Initialize unit and start again. If unit settled as required by user, the warning can be ignored.
11	Feedback Fail	Feedback signal is too weak or not present. Check if Feedback Photodiodes are connected properly.
12	Not used	
13	Not used	
14	Not used	
15	Not used	

The logo for IDPHOTONICS GMBH, featuring the company name in a blue, sans-serif font. The 'O' in 'PHOTONICS' is stylized with a circular arrow around it. 'GMBH' is in a smaller font to the right.

# SHAPING LIGHT.

HELPING ENGINEERS AND  
SCIENTISTS IN  
ADVANCING HOW THE  
WORLD COMMUNICATES,  
SENSES AND CONNECTS



TUNABLE  
LASER



TRANSMITTER  
SOLUTIONS

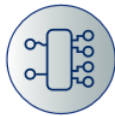

RECEIVER  
SOLUTIONS



SPECTRAL  
ANALYSIS



Anton-Bruckner-Strasse 6  
85579 Neubiberg  
GERMANY  
Tel: +49-89-201 899 16  
info@id-photonics.com  
id-photonics.com

All rights reserved. No part of this publication may be reproduced, stored in a retrieval system or transmitted in any form, be it electronically, mechanically, or by any other means such as photocopying, recording or otherwise, without the prior written permission of ID Photonics GmbH. Information provided by ID Photonics GmbH is believed to be accurate and reliable. However, no responsibility is assumed by ID Photonics GmbH for its use nor for any infringements of patents or other rights of third parties that may result from its use. No license is granted by implication or otherwise under any patent rights of ID Photonics GmbH. The information contained in this publication is subject to change without notice.